

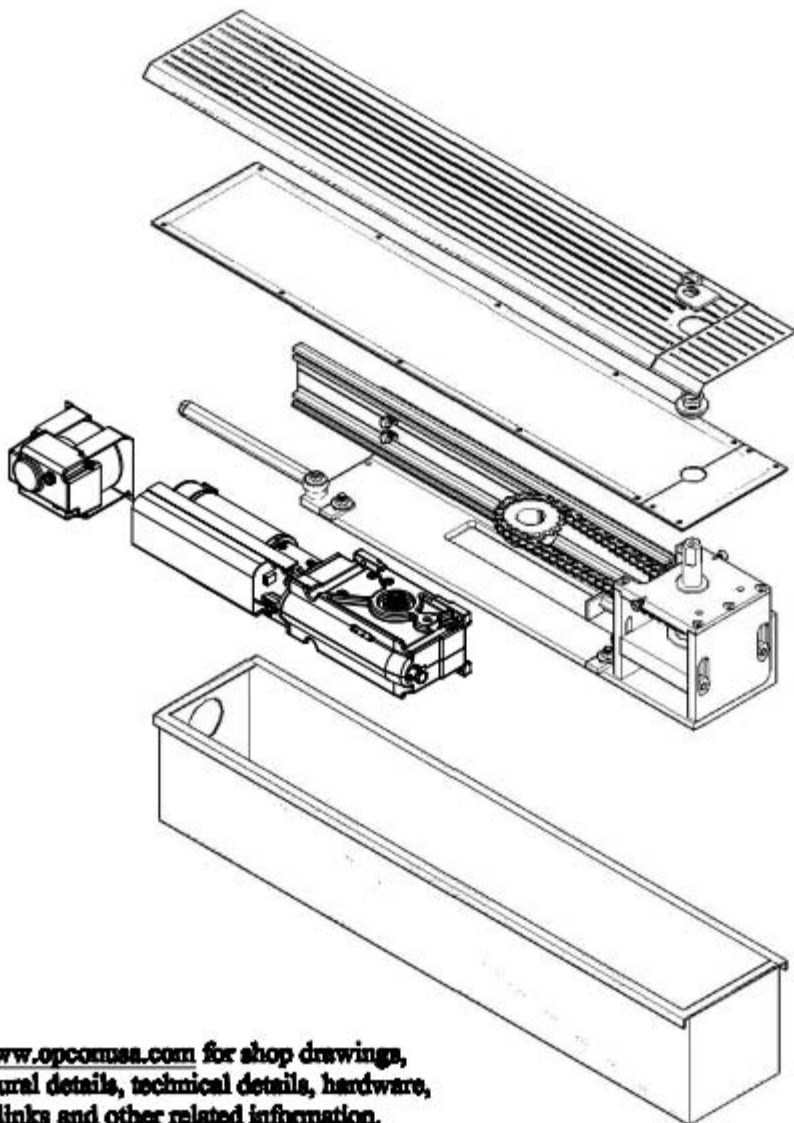

IN-FLOOR SWING DOOR OPERATORS
... WHERE DOOR AUTOMATION IS OUT OF SIGHT™

ASSEMBLY & INSTALLATION MANUAL

OPCON CONVERTER SYSTEM FOR RECORD 8000/8100- 6100



Go to www.opconusa.com for shop drawings,
architectural details, technical details, hardware,
product links and other related information.

INDEX

<u>TITLE</u>	<u>PAGE</u>
THEORY OF OPERATION & IMPORTANT CONSIDERATIONS	3
ISOMETRIC DRAWING WITH PARTS IDENTIFICATION	4
<u>ASSEMBLY PROCEDURE</u>	
OPERATOR ASSEMBLY (Procedure 1)	5
CHAIN & SPROCKET ASSEMBLY (Procedure 2)	6
CHAIN TENSIONING & TUNING (Procedure 3)	7
SPINDLE CENTERING & WEDGING (Procedure 4)	8
SPINDLE HEIGHT ADJUSTMENT (Procedure 5)	9
<u>SEALING</u>	
CEMENT CASE & SPINDLE SEALS (Procedure 6)	10
<u>FLOOR BLOCKOUT TEMPLATES</u>	
CENTER HUNG	11
13/16" OFFSET PIVOT HUNG (Standard Arms – Under Jamb Mounted)	12
BUTT HUNG (HINGED) (Standard Arms – Under Jamb Mounted)	13
BUTT HUNG (HINGED) (Bottom Slide Arm – Within Jambs)	14
NOTE: May also be used on 13/16" Offset Pivot Hung Doors.	
NOTE: See Door Prep Templates at Opcon Website for notch details	
<u>INSTALLATION PROCEDURES</u>	
CENTER HUNG DOORS	15
13/16" OFFSET PIVOT HUNG DOORS	16
BUTT HUNG (HINGED) DOORS	17
NOTE: May also be used on 13/16" Offset Pivot Hung Doors	
<u>FLOOR COVERINGS</u>	
THRESHOLDS, TERRAZZO & STONE PANS	18
<u>WIRING AND ELECTRICAL</u>	
ELECTRIC & LOW VOLTAGE CONDUIT CONNECTIONS	19
WIRING REQUIREMENTS – STANDARD INSTALLATION	20
WIRING REQUIREMENTS – ELECTRIC PANIC DEVICE	21
WIRING REQUIREMENTS – OVERHEAD ELECTRIC LOCK	22
WIRING REQUIREMENTS – BOTTOM RAIL ELECTRIC LOCK	23
WARRANTY	24
PATENTS	25

OPERATOR CONVERSION THEORY & IMPORTANT CONSIDERATIONS

(REVIEW BEFORE STARTING ASSEMBLY AND INSTALLTION)

THEORY OF OPERATION

The Opcon Operator Conversion System is designed to convert standard overhead mounted, swing door operators from overhead mounted to underground/underfloor use. A custom pivot assembly and operator-mounting sled is provided to attach the standard operator, creating a new drive assembly. The entire drive assembly is then placed into a waterproof cement case, sealed, and cemented into place under the door. The drive system Spindle attaches to the bottom arm of the door. The Spindle profile of the unit integrates with many available bottom arms for center hung and offset hung swing doors.

CONSIDERATIONS

- 1) **HANDING:** It is important to note that handing the operator is opposite of standard since the operator is mounted upside down when converted. Specifically, a left hand operator swings a right hand door; and a right hand operator swings a left hand door. Microswitch placement, stop block placement, and programming functions will be affected depending upon the operator selected.
- 2) **DRIVE SPINDLE:** The Spindle of the converter is specific to the bottom arm selected for each door. Spindle profiles are available for most Dorma and Rixson bottom arm hardware for center hung, offset pivot hung, and offset butt hung (hinged) doors. The Dorma arm profile is often compatible with CR Laurence hardware. Bottom arms are NOT supplied with the converter. Be certain that the Spindle ordered matches the bottom arm selected. See Opcon website for details.
- 3) **CEMENT CASE SIZE:** All cement cases are supplied at the standard size of 35-1/2" long X 7" wide. On pairs of doors, a conduit connects the cement cases and the width is variable. Pairs of doors narrower than 72" are available as a custom order. Contact Opcon for custom size details.
- 4) **FLOOR EXCAVATION & PREPARATION:** The typical floor depth for the converter is 7" minimum; but this may be reduced somewhat by the height of the threshold or other flooring material if the converter can be raised under the floor covering. Center hung door excavation is the width between the jambs + 1/4" under the jambs; Offset hung door excavation is the width between the jambs + 2-1/4" under the pivot side jambs. Refer to Floor Blockout tab at Opcon website.
- 5) **THRESHOLD & FLOORING:** All units are shipped considering a 1/2" tall threshold or stone cover unless otherwise advised. Most thresholds must be 10" wide to cover the converter and excavation. Terrazzo/stone pans have a variable size between 8" and 10". Thresholds made to Opcon specifications are available directly from National Guard Products or Pemko. Terrazzo & Stone Pans are also available for stone flooring directly from Opcon. Refer to Thresholds at website.
- 6) **ELECTRICAL & LOW VOLTAGE:** The electrical supply and low voltage signal lines must enter the cement case at the non-pivot side of the converter on single doors, and at or near the center on pairs of doors. Liquid Tight conduit fittings must be installed. Wireless activation requires sealed antennae placement through the cement case. Refer to Wiring section of Install Manual.

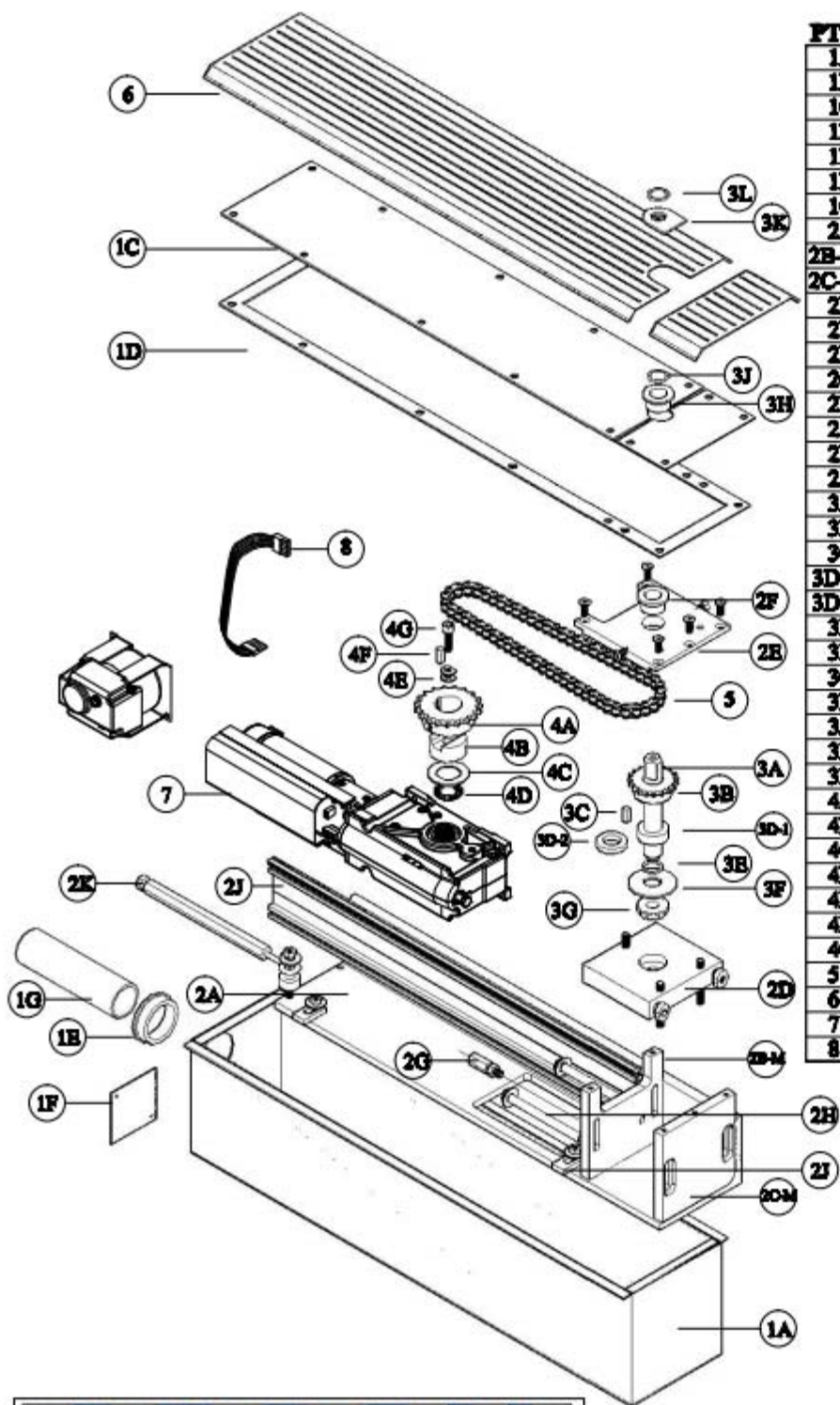

PTN/ DESCRIPTION

1A	CEMENT CASE
1B	CEMENT CASE COVER
1C	CEMENT CASE COVER
1D	PERIMETER GASKET
1E	CASE COUPLER P/PAIRS
1F	COUPLER COVER P/SINGLES
1G	CONDUIT CONNECTOR
2A	SLED BASE
2B-M	FRONT PIVOT HOUSING RIBBER
2C-M	REAR PIVOT HOUSING RIBBER
2D	BASE PLATE
2E	TOP PLATE
2F	LATERAL BUSHING
2G	CHAIN TENSIONER
2H	BASE PLATE BOLT (2)
2J	LATERAL WEDGH (2)
2K	LATERAL HEX WEDGE
2L	MOTOR MOUNT EXTRUSION
3A	PIVOT ARM SPINDLE
3B	SPINDLE SPROCKET
3C	SHAFT KEY
3D-1	STD. ANTI-SLIP COLLAR P/KEY
3D-2	ALT. ANTI-SLIP COLLAR P/KEY
3E	"O" -RING
3F	BEARING COVER
3G	TAPERED BEARING
3H	SPINDLE SEAL
3J	"O" -RING SEAL
3K	THRESHOLD SEAL
3L	"O" -RING SEAL
4A	DRIVE SPROCKET
4B	SPROCKET HUB
4C	BRONZE THRUST WASHER
4D	NEEDLE BEARING
4E	CLIPPED WASHER (2)
4F	SHAFT KEY
4G	MOUNTING BOLT
5	DRIVE CHAIN OR BELT
6	THRESHOLD ASSY.
7	OPERATOR ASSY.
8	FLASH PROGRAMMER CABLE



**RECORD 8000/8100-6100
UNDERGROUND CONVERSION**



OPERATOR ASSEMBLY

(PROCEDURE 1)

RECORD 8000/8100-6100

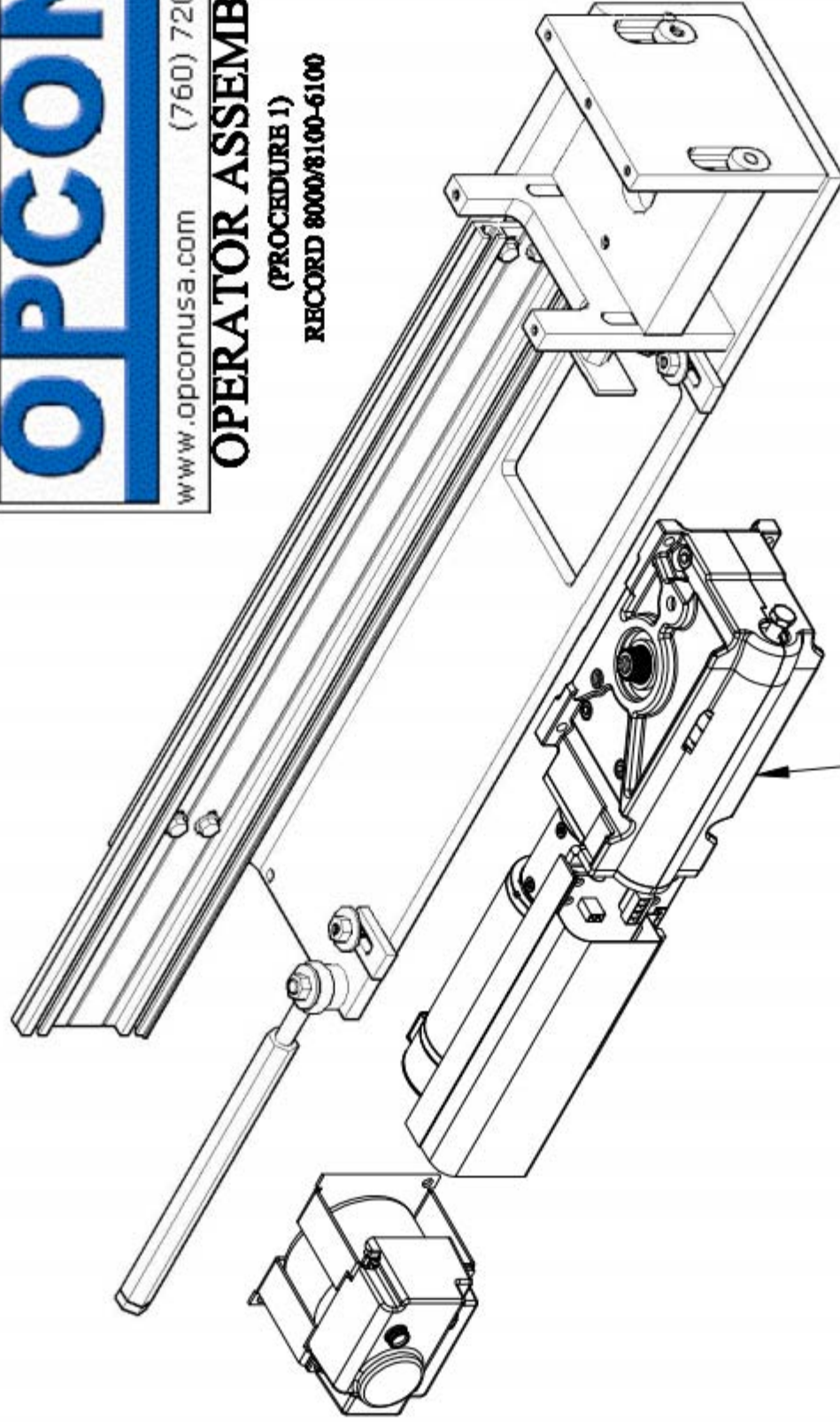

STEP 1: Mount operator to sled extrusion. Slide forward to provide space to mount chain.

NOTES/PROCEDURE:

1. Reference isometric drawing for more details.
2. Right hand outswing shown; uses left hand outswing operator due to upside-down mounting
3. After mounting, power operator to 90° hold open stop (internal operator stop).
4. See chain and sprocket assembly to continue.

STEP 2: Install gearbox sprocket/hub assy sequenced as shown. Power unit open to full 90° position.

STEP 3: Install chain over gearbox sprocket; index spindle to full open position; tilt spindle to place chain over sprocket.

STEP 4: Re-install top plate.

STEP 1: Remove top plate & install drive spindle parts sequenced as shown.

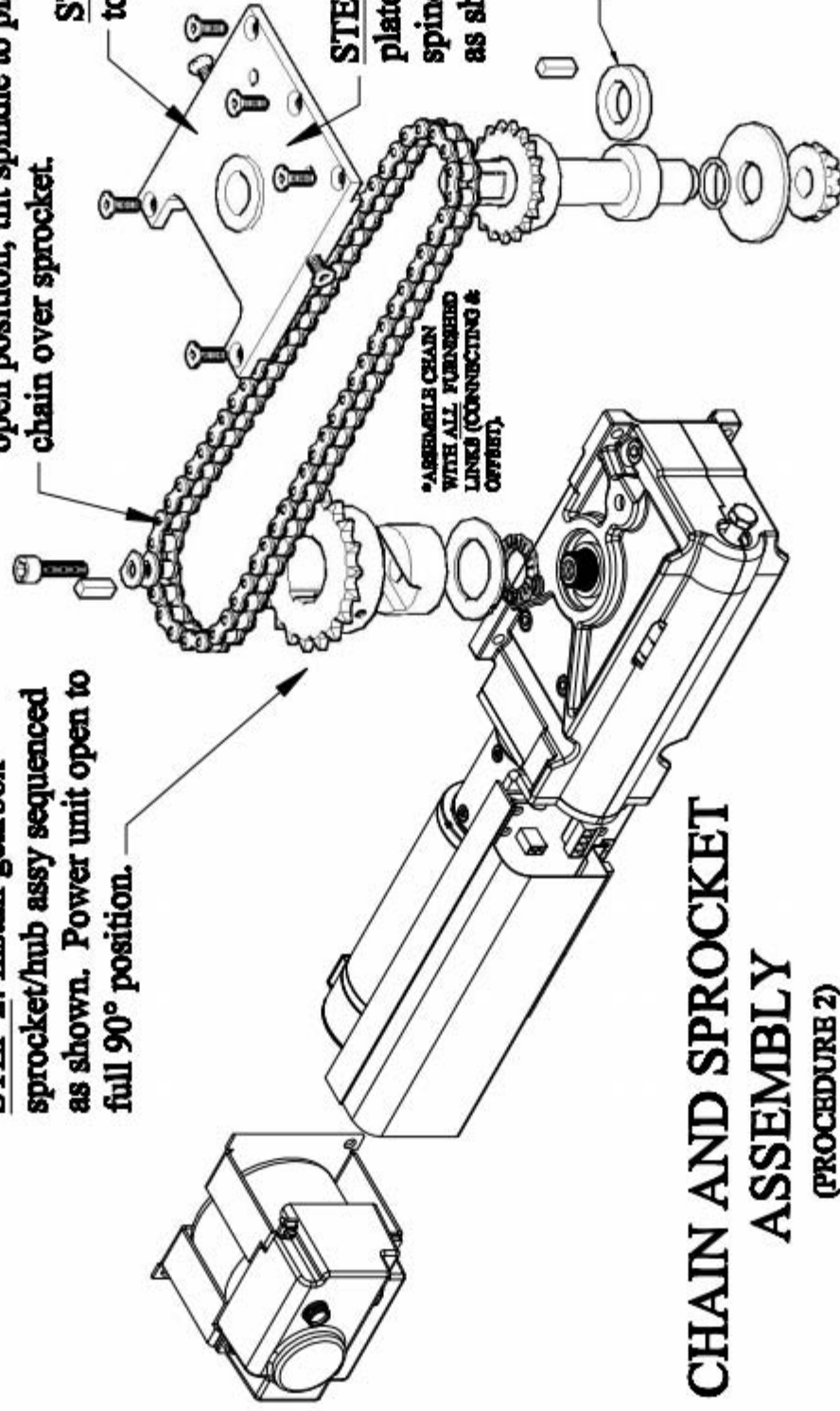

*ASSEMBLE CHAIN WITH ALL FURNISHED LINES (CONNECTING & OFFSET)

*ALT SPINDLE COLLAR (JAW) USE WHEN SPINDLE MUST BE RAISED HIGHER THAN 91/2" SPINDLE COLLAR PERMIT.

CHAIN AND SPROCKET ASSEMBLY

(PROCEDURE 2)

RECORD 800/8100-6100



www.opconusa.com (760) 720-3902

NOTES/PROCEDURE:

1. From procedure #1, operator is mounted to sled and powered to 90° open position before installing chain and sprockets.
2. After chain and sprocket assembly, slide operator away from spindle to tension chain (see procedure 3).

OPCON™

www.opconusa.com (760) 720-3902

CHAIN TENSION & TUNE

(PROCEDURE 3)

RECORD 8000/8100-6100

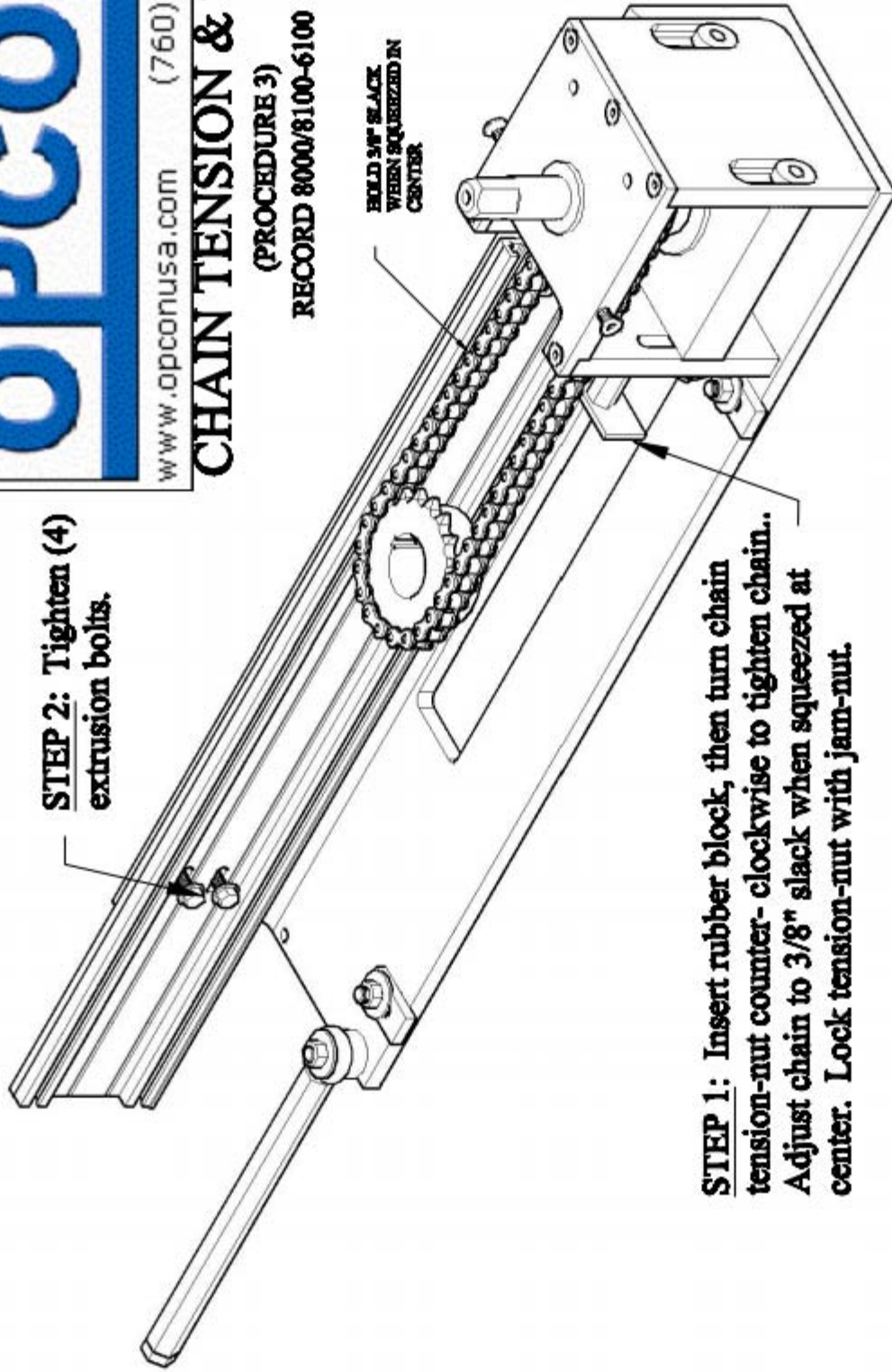

NOTES/PROCEDURES:

1. Operator and speed control not shown for clarity.
2. Adjust opening and closing positions of spindle (pre-load for closing force).
3. Attach control box and tune to Record specifications.
4. Install completed and tuned assembly into cement case.

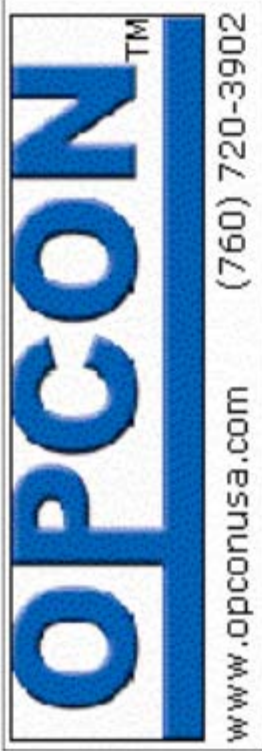

SPINDLE CENTERING & WEDGING

(PROCEDURE 4)
RECORD 8000/8100-6100

STEP 1: Center spindle using 2 bolts on top plate. Minimize pressure on cement case to avoid misalignment of cover screws.

STEP 2: Adjust hex bar for lateral movement. Insert shims behind spindle housing for alternate spindle locating.

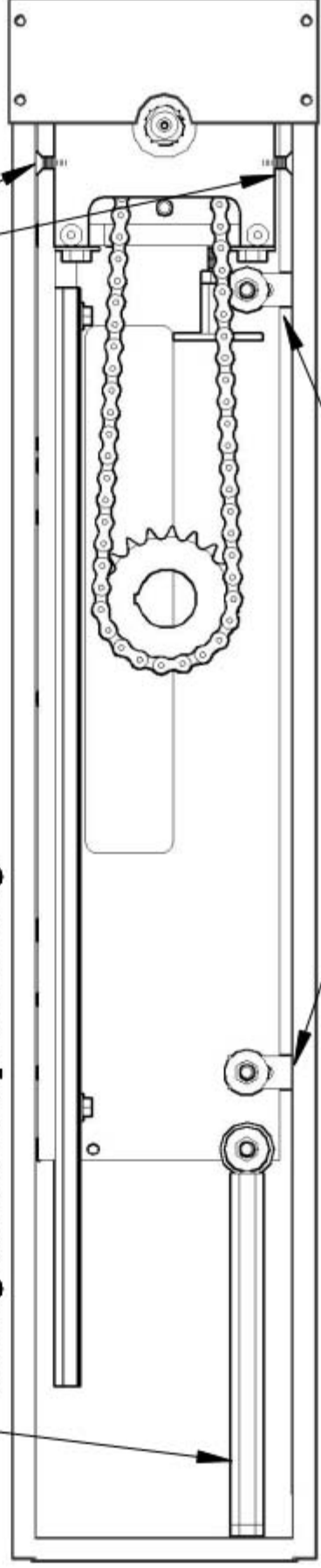

STEP 3: Tighten sled wedges in 2 places. Wedge flat and tight against cement case.

NOTES/PROCEDURES:

- 1. Operator and speed control not shown for clarity.
- 2. Insert tuned converter/operator assembly into cement case.
- 3. Adjust spindle to center of cement case using adjusting bolts and hex bar.
- 4. Wedge sled assembly firmly within cement case.



SPINDLE HEIGHT ADJUSTMENT

(PROCEDURE 5)

RECORD 8000/8100-6100

STEP 1: Loosen (2) 9/16" base plate bolts. Do not remove.

STEP 3: Re-tighten (2) 9/16" base plate bolts.

Spindle shoulder

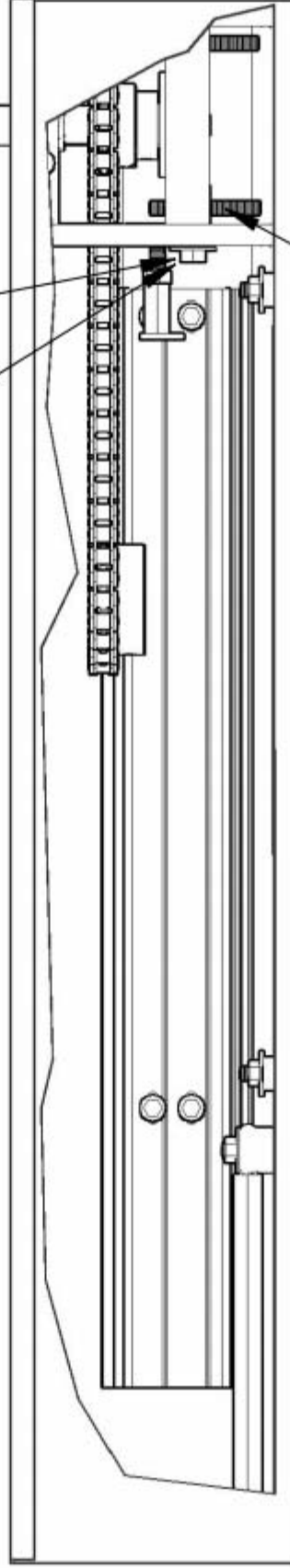

STEP 2: Adjust base-plate height using Allen wrench on 3 threaded posts. Turn clockwise to raise; turn counter-clockwise to lower. Turn each post equally.

NOTES/PROCEDURES:

1. Operator and speed control not shown for clarity.
2. Spindle height adjustment formula:

ASSUMES CEMENT CASE COVER IS 1/4" BELOW FINISHED FLOOR AT INSTALLATION.
DIMENSIONS TAKEN FROM TOP OF CEMENT CASE COVER TO SPINDLE SHOULDER.

1/4" BELOW FINISHED FLOOR + THRESHOLD HEIGHT + SPACE BENEATH DOOR +

DEPTH OF BOTTOM ARM IF ARM IS RECESSED INSIDE BOTTOM OF DOOR (MAX RECESS 1/8").

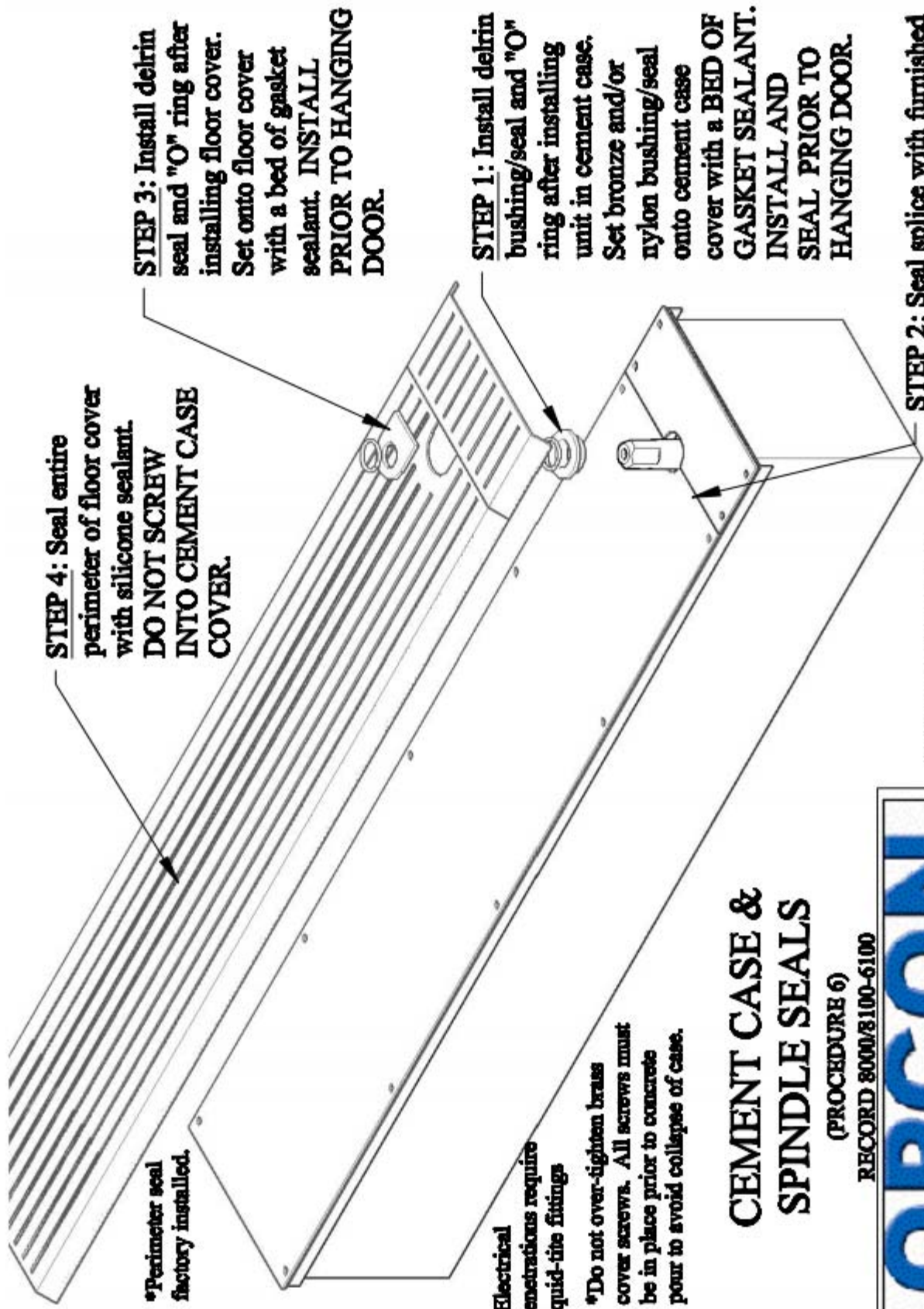

STEP 4: Seal entire perimeter of floor cover with silicone sealant. **DO NOT SCREW INTO CEMENT CASE COVER.**

STEP 3: Install delrin seal and "O" ring after installing floor cover. Set onto floor cover with a bed of gasket sealant. **INSTALL PRIOR TO HANGING DOOR.**

STEP 1: Install delrin bushing/seal and "O" ring after installing unit in cement case. Set bronze and/or nylon bushing/seal onto cement case cover with a **BED OF GASKET SEALANT. INSTALL AND SEAL PRIOR TO HANGING DOOR.**

STEP 2: Seal splice with furnished gasket sealant. Leave sealant inside cement case for future access.

*Perimeter seal factory installed.

*Electrical penetrations require liquid-tite fittings

*Do not over-tighten brass cover screws. All screws must be in place prior to concrete pour to avoid collapse of case.

*See "Thresholds" tab at website for other floor covering options (terrazzo, stone, transition, etc.).

CEMENT CASE & SPINDLE SEALS

(PROCEDURE 6)

RECORD 8000/8100-6100



www.opconusa.com (760) 720-3902



**FIELD LAYOUT TEMPLATE
 FLOOR BLOCKOUT
 CENTER HUNG DOORS**

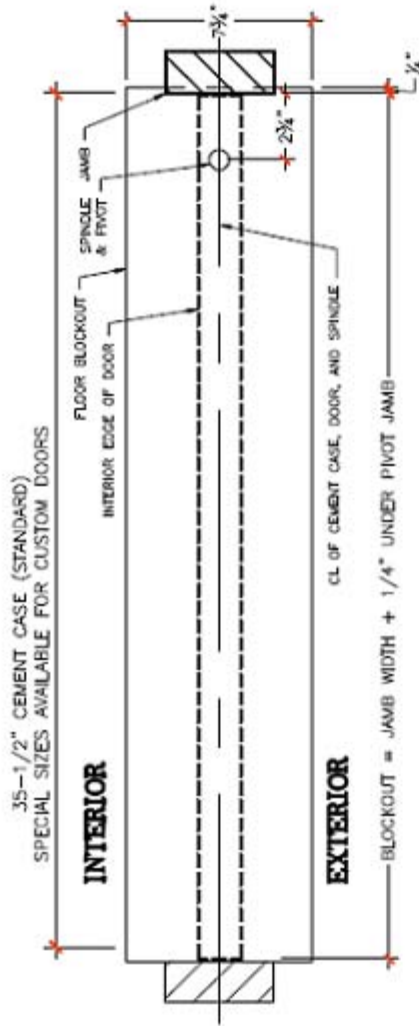

**SINGLE DOOR : LEFT HAND OUTSWING (RHR) SHOWN
 RIGHT HAND OUTSWING (LHR) OPPOSITE**

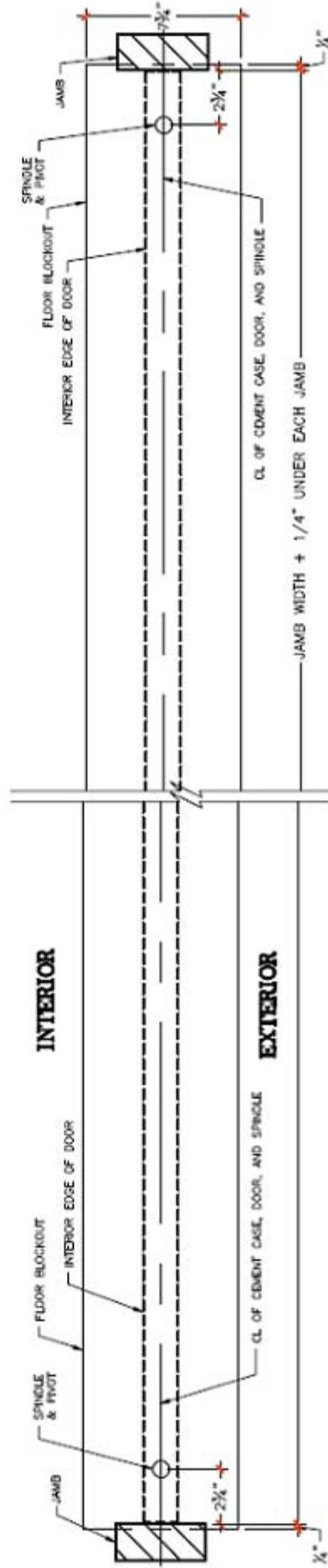

OUTSWING DOOR PAIR

NOTES

1. CENTER HUNG DOORS ONLY. DIMENSIONS DIFFERENT ON OFFSET PIVOT AND BUTT HUNG DOORS
2. SEE MANUFACTURERS TEMPLATE FOR LATEST DOOR LEAF AND BOTTOM ARM PREP
3. DEPTH OF EXCAVATION IS 7.125 MINIMUM TO 7.75 MAXIMUM BELOW FINISHED FLOOR
4. SPINDLE CENTER MUST BE PLUMB WITH TOP PIVOT

FL-C101

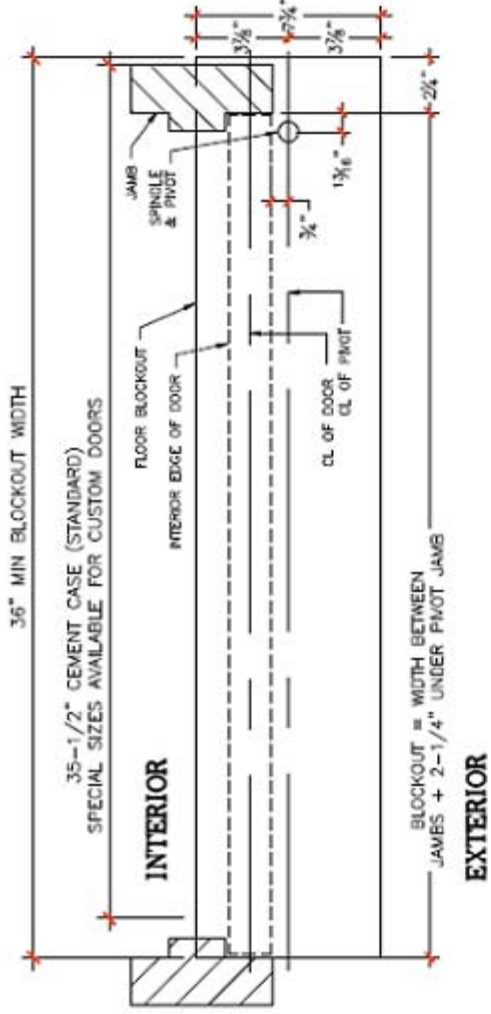

FIELD LAYOUT TEMPLATE
FLOOR BLOCKOUT WITH STANDARD
BOTTOM ARMS ONLY
 (RIXSON #27 OR DORMA BTS-80, ETC.)
1 3/16" OFFSET PIVOT HUNG DOORS ONLY

SINGLE DOOR : LEFT HAND OUTSWING (RHR) SHOWN
RIGHT HAND OUTSWING (LHR) OPPOSITE

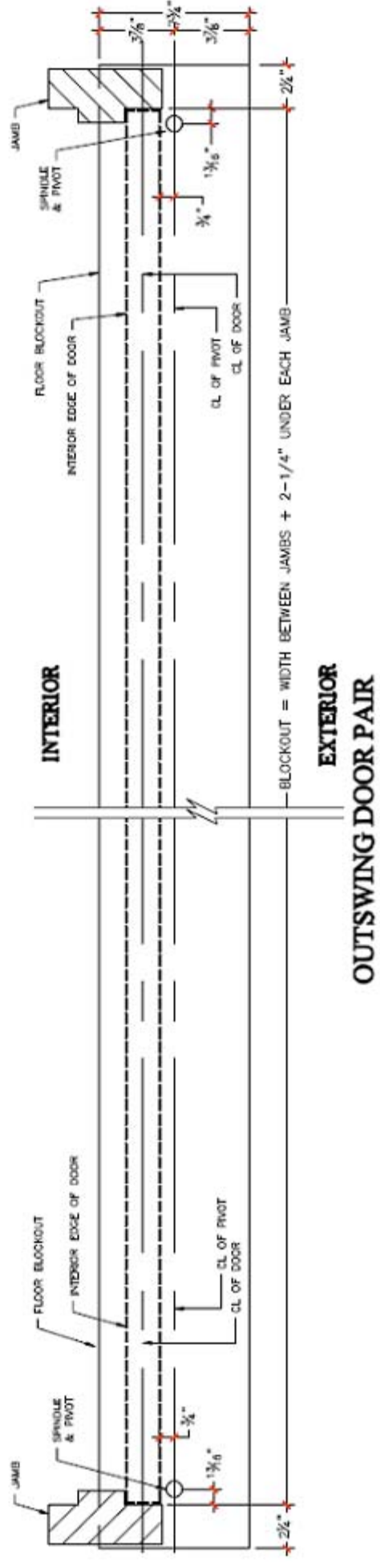

NOTES

1. 1 3/16" OFFSET PIVOT DOORS USING STANDARD BOTTOM ARMS ONLY. DIMENSIONS DIFFERENT ON BUTT HUNG (HINGED), OFFSET SLIDE-ARM, AND CENTER-HUNG DOORS
2. SPINDLE MUST BE PLUMB WITH PIVOT CENTER. SEE MANUFACTURER'S CURRENT TEMPLATE FOR BOTTOM ARM PLACEMENT ON DOOR
3. DEPTH OF EXCAVATION IS 7.125 MINIMUM TO 7.75 MAXIMUM BELOW FINISHED FLOOR

FL-P101-S27



FIELD LAYOUT TEMPLATE
FLOOR BLOCKOUT WITH STANDARD
BOTTOM ARMS ONLY
(RDXSON #27 OR DORMA BTS-80, ETC.)
BUTT HINGED - OFFSET HUNG DOORS ONLY

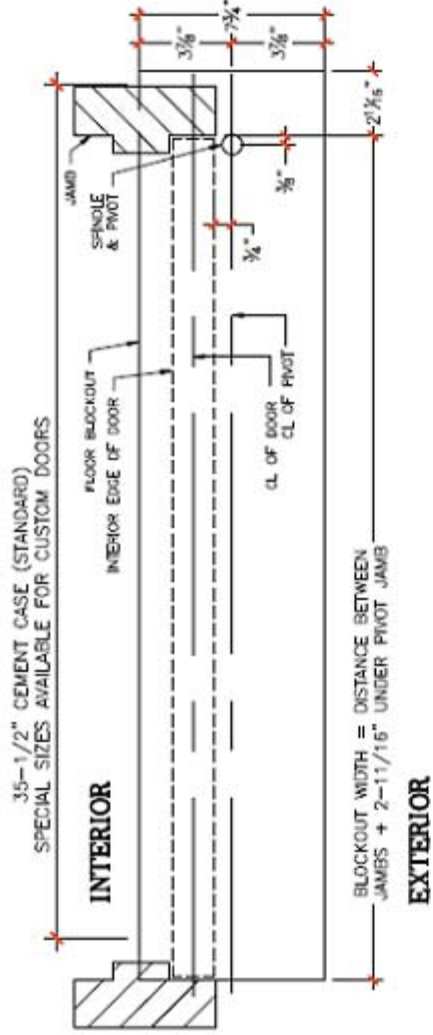

SINGLE DOOR : LEFT HAND OUTSWING (RHR) SHOWN
RIGHT HAND OUTSWING (LHR) OPPOSITE

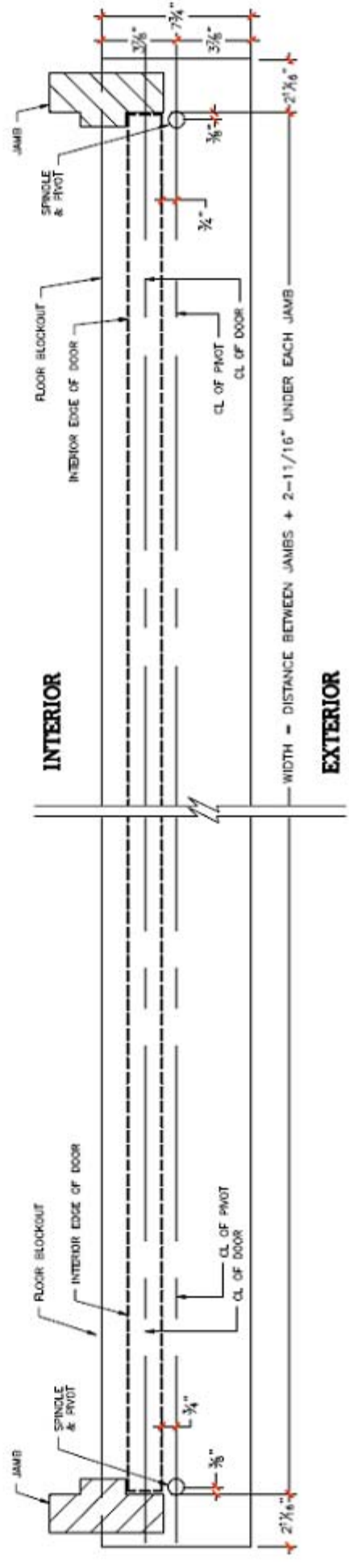

- NOTES**
1. OFFSET BUTT- HUNG DOORS USING STANDARD BOTTOM ARMS ONLY. DIMENSIONS DIFFERENT ON OFFSET PIVOT, OFFSET SLIDE-ARM, AND CENTER-HUNG DOORS
 2. SPINDLE MUST BE PLUMB WITH HINGE CENTER. BOTTOM ARM PLACEMENT ON DOOR WILL DIFFER FROM MANUFACTURER'S TEMPLATE.
 3. DEPTH OF EXCAVATION IS 7.125 MINIMUM TO 7.75 MAXIMUM BELOW FINISHED FLOOR

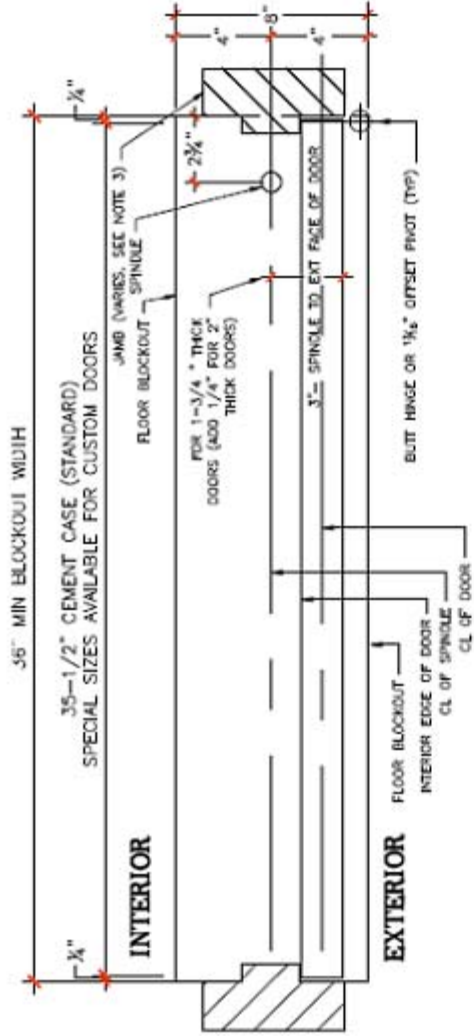

**SINGLE DOOR : LEFT HAND OUTSWING (RHR) SHOWN
RIGHT HAND OUTSWING (LHR) OPPOSITE**

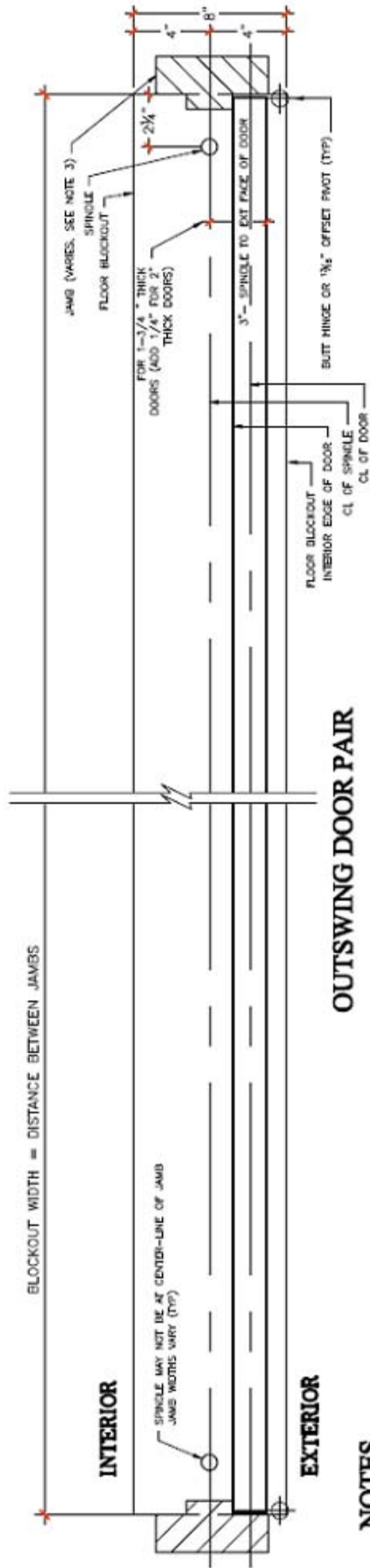

NOTES

1. BUTT HUNG (HINGED) & 1³/₁₆" OFFSET PIVOT DOORS USING DORMA BOTTOM ARM AND SLIDE TRACK ONLY.
2. DIMENSIONS ARE FOR DOOR THICKNESS SHOWN. ALTER DIMENSIONS PROPORTIONATELY FOR OTHER THICKNESS
3. JAMB WIDTHS VARY. PLACEMENT DIMENSIONS ARE FROM EXTERIOR FACE OF DOOR TO CENTER OF SPINDLE.
4. SEE OPCON WEBSITE FOR LATEST DOOR LEAF PREP DRAWINGS
5. DEPTH OF EXCAVATION IS 7.125 MINIMUM TO 7.75 MAXIMUM BELOW FINISHED FLOOR

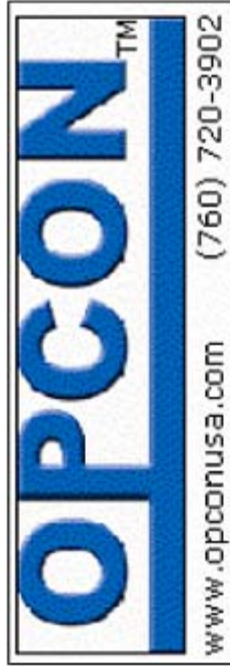

**FIELD LAYOUT TEMPLATE
FLOOR BLOCKOUT FOR BOTTOM SLIDE-ARMS
USING DORMA BTS-81 W/745IN SLIDE TRACK OR
RIXSON #327 BOTTOM ARM W/SLIDE TRACK
BUTT HUNG (HINGED) AND 1³/₁₆" OFFSET PIVOT DOORS**

REF. WEB DWGS
FL-P101-D81
FL-B101-D81
FL-P101-R327
FL-B101-R327

INSTALLATION PROCEDURE

ALL MANUFACTURERS - ALL STANDARD OPERATORS

CENTER HUNG DOORS

2 $\frac{3}{4}$ " Pivot Setback (Rixson #28, Dorma BTS-80, etc.)

1. Cut concrete or floor to dimensions detailed on blockout/template drawing. Blockout must be entire door width between jambs + $\frac{1}{4}$ " under each pivot jamb.
2. Layout & drill cement case for electrical & signal lines
3. Install electric & low voltage conduit with liquid-tite fittings.
4. Install top door pivot & locate center of OPCON converter spindle using a plumb-bob/laser.
5. Cement case must be parallel with door header. CEMENT CASE COVER IS SET $\frac{1}{4}$ " BELOW FINISHED FLOOR (min.).
6. For PAIRS of doors the cases will be set separately with a connecting conduit at center.
7. Cement case must be level & plumb in all directions.
8. Set cement case into excavation & secure in position.
9. Pourstone ONLY around bottom 1" of cement case. INSTALL SPINDLE/SHAFT SEALS NOW. Hang door and final adjust position.
10. BE SURE THAT CEMENT CASE COVER IS INSTALLED PRIOR TO POURSTONE. POURSTONE WILL COLLAPSE THE CEMENT CASE IF COVER IS NOT ATTACHED.
11. Final pourstone cement case with OPCON converter assembly & door leaf in place.

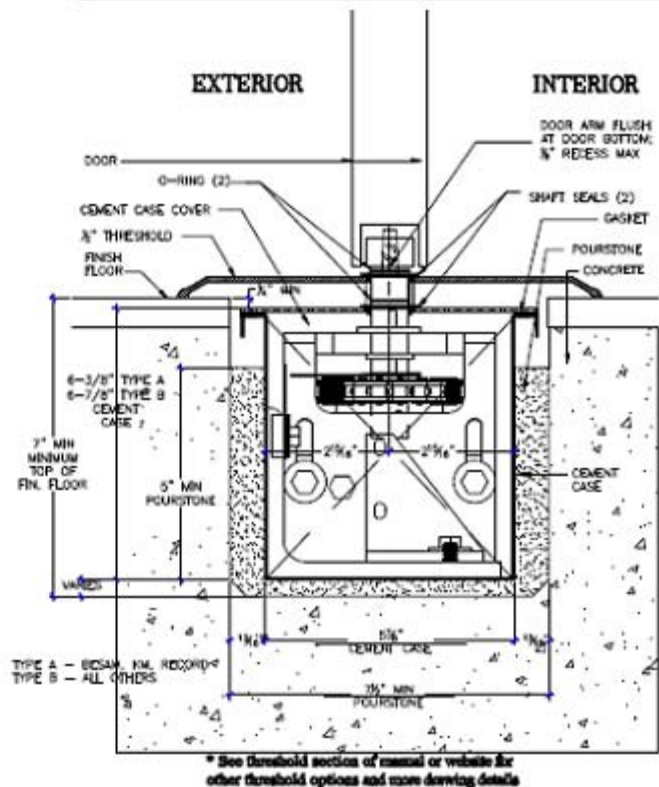

NOT TO SCALE

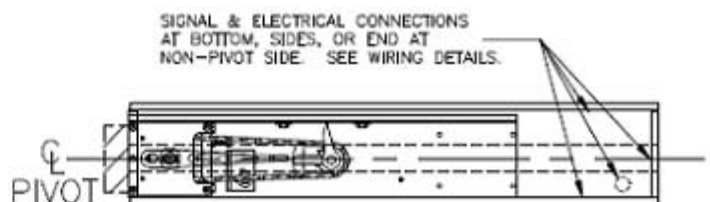
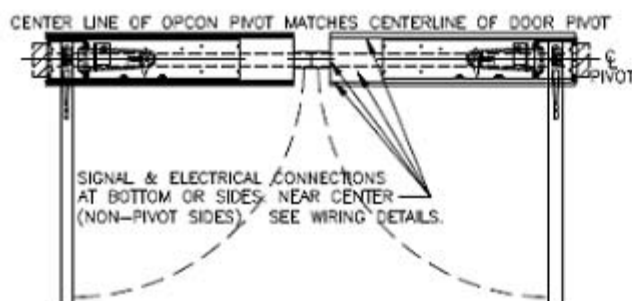
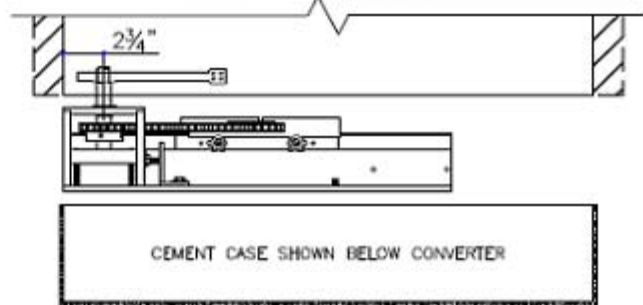
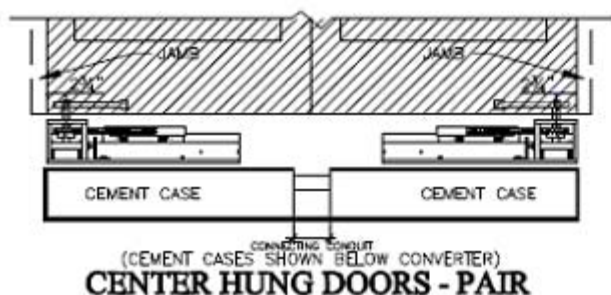

INSTALLATION PROCEDURE

ALL MANUFACTURERS - ALL STANDARD OPERATORS
OFFSET (PIVOT) HUNG DOORS
 13/16" Pivot Setback (Rixson #27, Dorma BTS-80, etc.)



1. Cut concrete or floor to dimensions detailed on blockout/template drawing. Blockout must be entire door width between jambs + 2 1/4" under each pivot jamb.
2. Layout & drill cement case for electrical & signal lines
3. Install electric & low voltage conduit with liquid-tite fittings.
4. Install top door pivot & locate center of OPCON converter converter spindle using a plumb-bob/laser.
5. Cement case must be parallel with door header. **CEMENT CASE COVER IS SET 1/4" BELOW FINISHED FLOOR (min.).**
6. For PAIRS of doors the cases will be set separately with a connecting conduit at center.
7. Cement case must be level & plumb in all directions.
8. Set cement case into excavation & secure in position.
9. Pourstone ONLY around bottom 1" of cement case. **INSTALL SPINDLE/SHAFT SEALS NOW. Hang door and final adjust position.**
10. **BE SURE THAT CEMENT CASE COVER IS INSTALLED PRIOR TO POURSTONE. POURSTONE WILL COLLAPSE THE CEMENT CASE IF COVER IS NOT ATTACHED.**
11. Final pourstone cement case with OPCON converter assembly & door leaf in place.

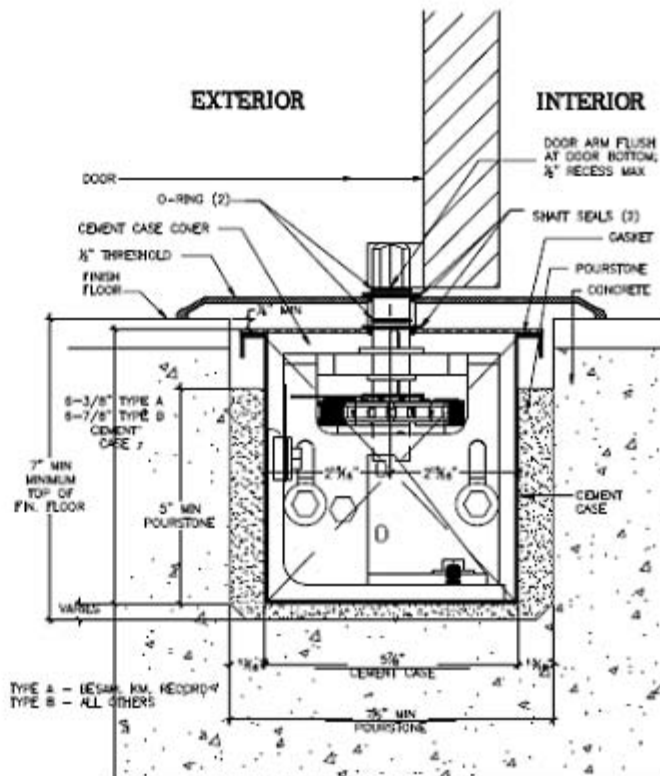

*See threshold section of manual or website for other threshold options and more drawing details.

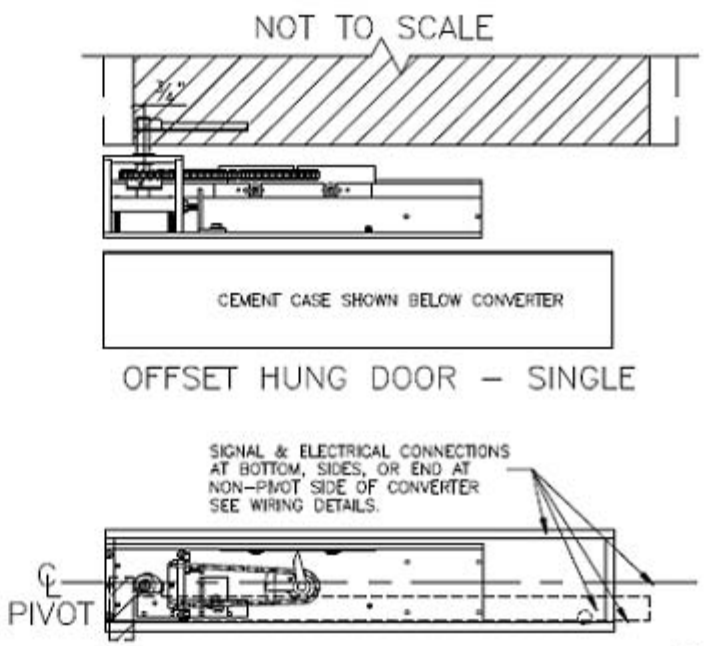
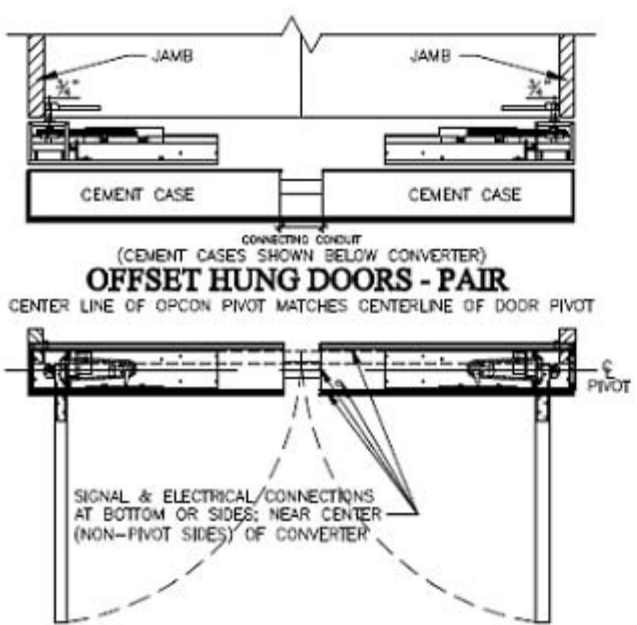

INSTALLATION PROCEDURE

ALL MANUFACTURERS - ALL STANDARD OPERATORS

BUTT-HUNG (HINGED) DOORS

Hinged Setback (Dorma #7451N Slide-arm or Rixson #327)



1. Cut concrete or floor to dimensions detailed on blockout/template drawing. Blockout must be entire door width between jambs.
2. Layout & drill cement case for electrical & signal lines
3. Install electric & low voltage conduit with liquid-tite fittings.
4. Establish location of exterior door face & locate center of OPCON converter spindle. DRAWING ASSUMES 1-3/4" THICK DOOR, ADJUST DIMENSIONS FOR THICKER OR THINNER DOORS.
5. Cement case must be parallel with door header. CEMENT CASE COVER IS SET 1/4" BELOW FINISHED FLOOR (min.).
6. For PAIRS of doors the cases will be set separately with a connecting conduit at center.
7. Cement case must be level & plumb in all directions.
8. Set cement case into excavation & secure in position.
9. Pourstone ONLY around bottom 1" of cement case. INSTALL SPINDLE/SHAFT SEALS NOW. Hang door and final adjust position.
10. BE SURE THAT CEMENT CASE COVER IS INSTALLED PRIOR TO POURSTONE. POURSTONE WILL COLLAPSE THE CEMENT CASE IF COVER IS NOT ATTACHED.
11. Final pourstone cement case with OPCON converter assembly & door leaf in place.

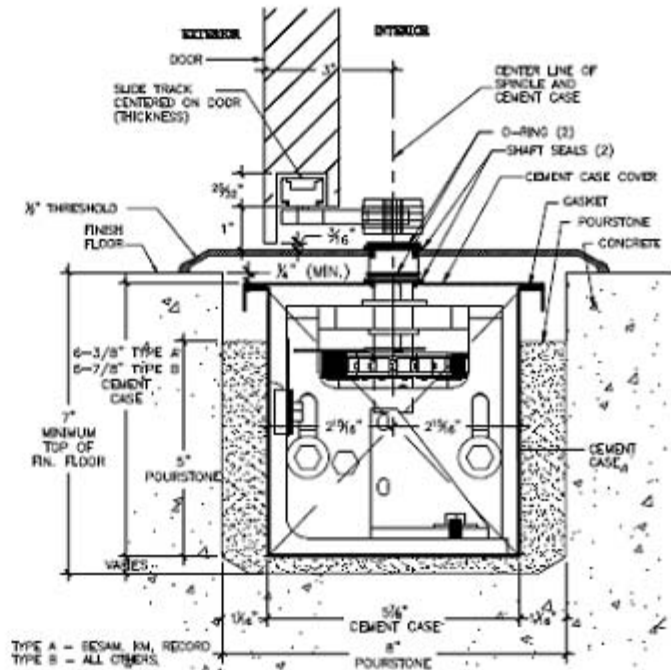

*See threshold section of manual or website for other threshold options and more drawing details.
*See door leaf prep template for bottom slide-arm details

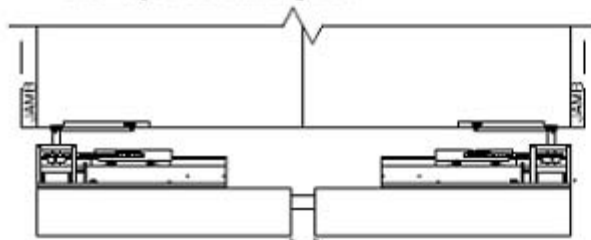

(CEMENT CASES SHOWN BELOW CONVERTER)
OFFSET HUNG DOORS - PAIR

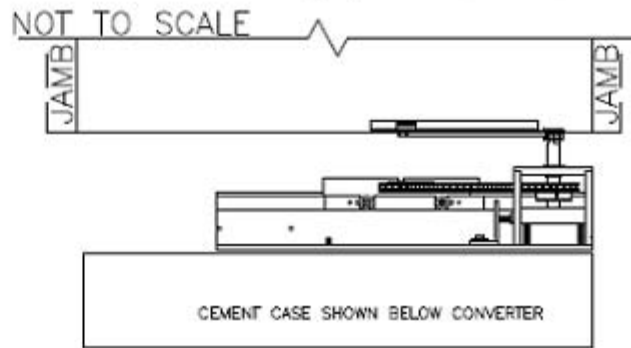
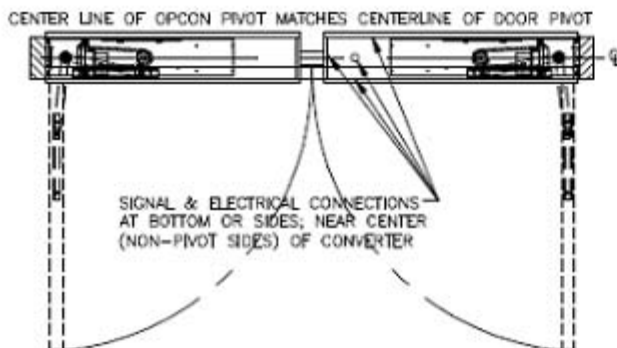

OFFSET HUNG DOOR - SINGLE

SIGNAL & ELECTRICAL CONNECTIONS AT BOTTOM, SIDES, OR END AT NON-PIVOT SIDE OF CONVERTER SEE WIRING DETAILS.

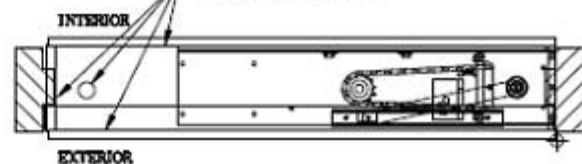

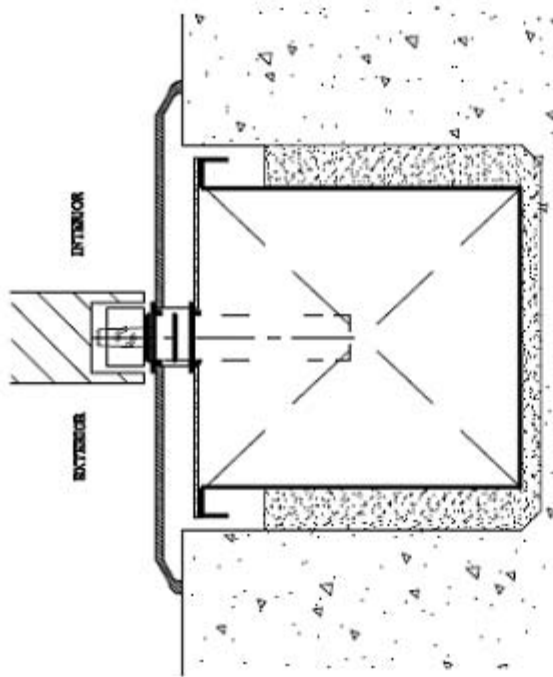

END VIEW W/STANDARD THRESHOLD CENTER HUNG

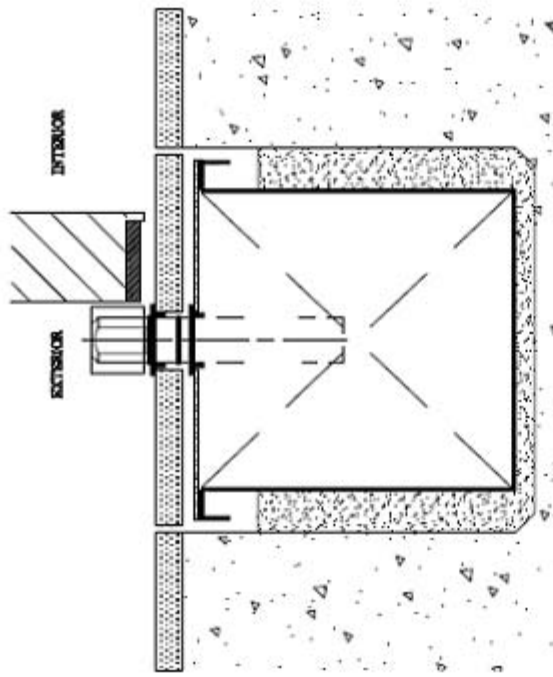

END VIEW W/TERRAZZO OR STONE PAN - OFFSET PIVOT HUNG

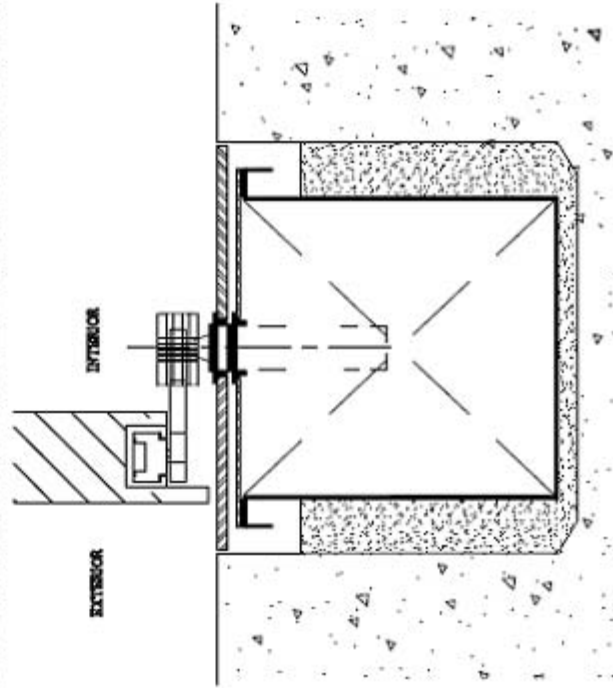

END VIEW W/FLUSH (TRANSITION) THRESHOLD - BUTT HUNG (HINGED) WITH BOTTOM SLIDE-ARM

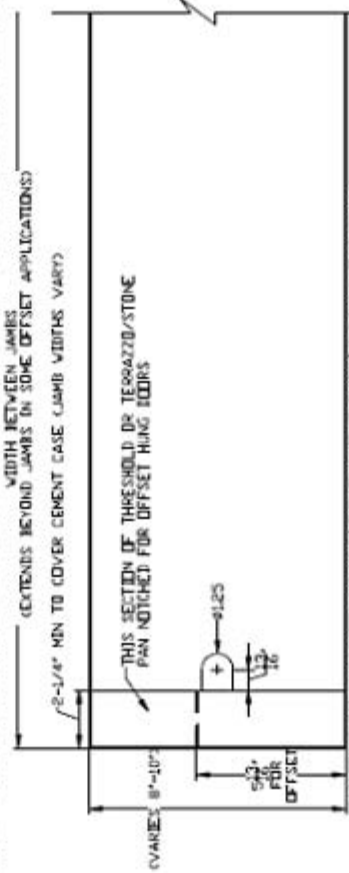

PLAN VIEW - TYPICAL FLOOR COVER PREP
***SEE WEBSITE FOR DETAILED DRAWINGS & OPTIONS**
FLOOR COVERING OPTIONS

OPCON™
www.opconusa.com (760) 720-3902

CONDUIT CONNECTIONS

ELECTRIC & LOW VOLTAGE LINES

TYPICAL FOR ALL INSTALLATIONS
(Standard System for Dual Cement Case)



1. Verify power requirements with operator manufacturer & layout cement case for conduit.
2. Verify low voltage signal lines for accessories & layout cement case for conduit.
3. Conduit to Cement Case Connection must be "liqui-tite" (or equal) water tite fittings. Field drilled as required. Conduit & fittings required for both 120VAC and low voltage signal runs.
4. Conduit connections to convertor must be at the strike side of single doors and near center of dual doors as shown. Holes may be located at sides, bottom, or end (on single doors) of cement case. Use silicone sealant to seal penetrations if necessary.

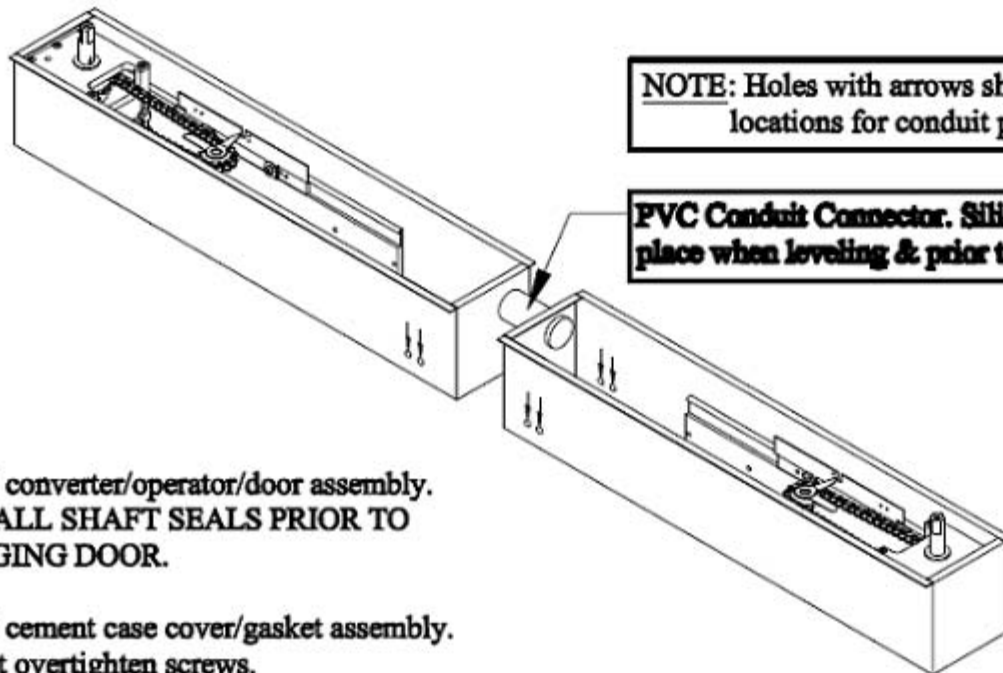
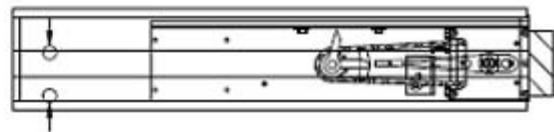
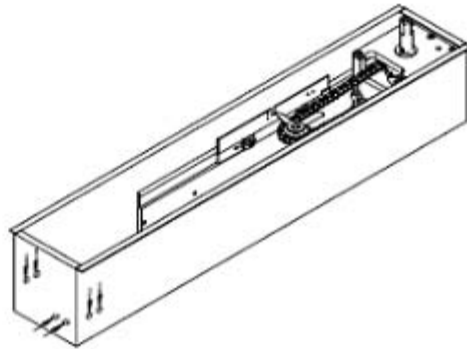

NOTE: Holes with arrows show the best locations for conduit penetrations

PVC Conduit Connector. Silicone in place when leveling & prior to pourstone.

5. Install converter/operator/door assembly.
INSTALL SHAFT SEALS PRIOR TO HANGING DOOR.
6. Install cement case cover/gasket assembly.
Do not overtighten screws.

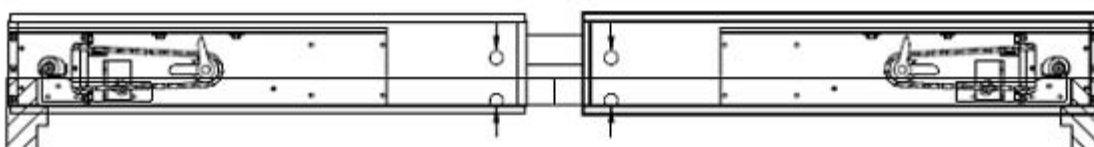

WIRING REQUIREMENTS STANDARD INSTALL

ALL WIRING TO NON-Pivot SIDE OF DOOR LEAF. WIRES TO CENTER ON PAIRS; WIRES TO STRIKE SIDE ON SINGLES. SEE ELECTRICAL PENETRATION DRAWING IN MANUAL FOR CONDUIT FITTING LOCATION ON CEMENT CASE. SEE OPERATOR MANUFACTURER'S MANUAL FOR SPECIFIC WIRING REQUIREMENTS

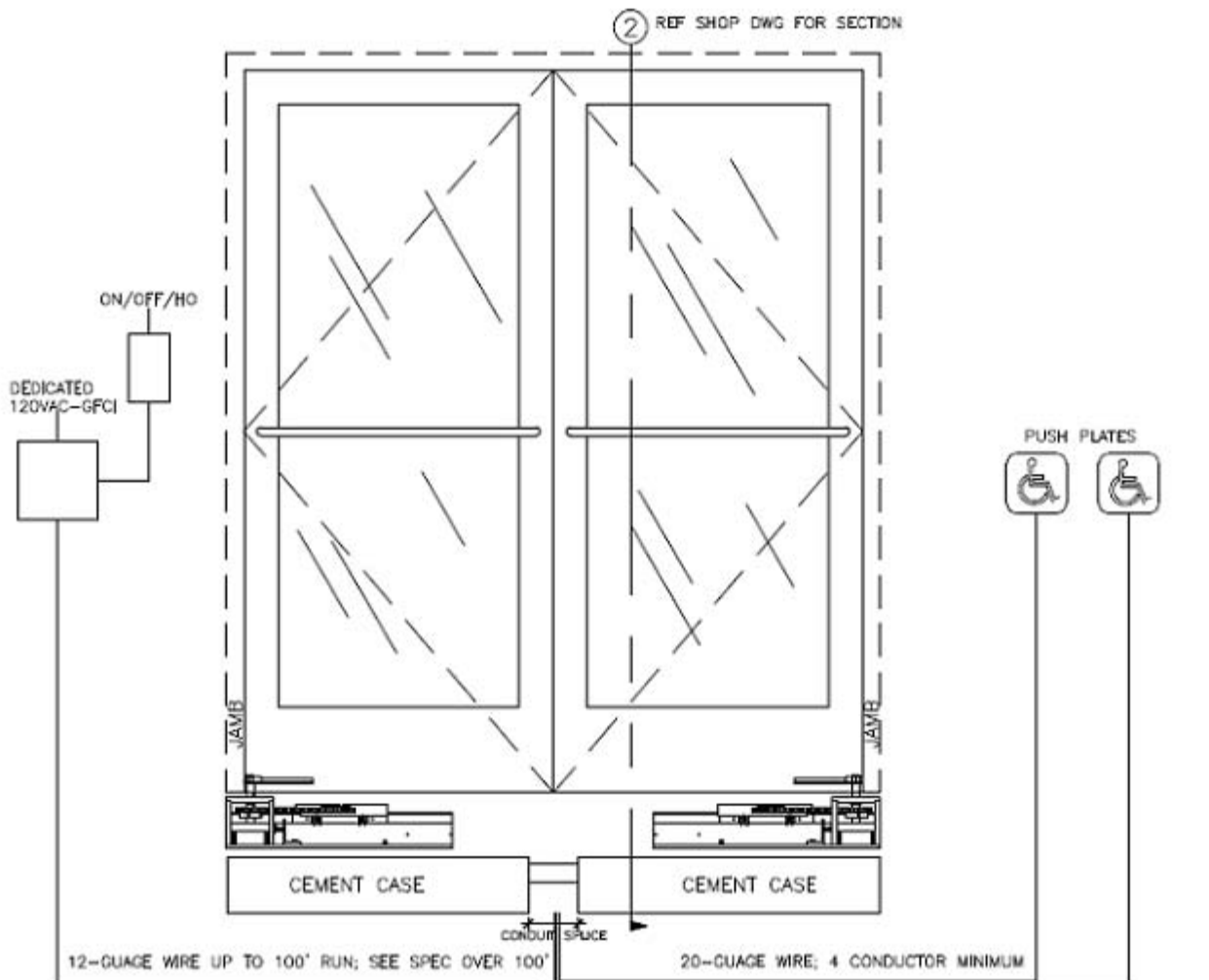

FRONT ELEVATION ③ SCALE = 1:20

CEMENT CASES SHOWN BELOW SLEDS FOR CLARITY
SINGLE DOOR WIRING SIMILAR—USE LIQUID TIGHT CONDUIT FITTINGS

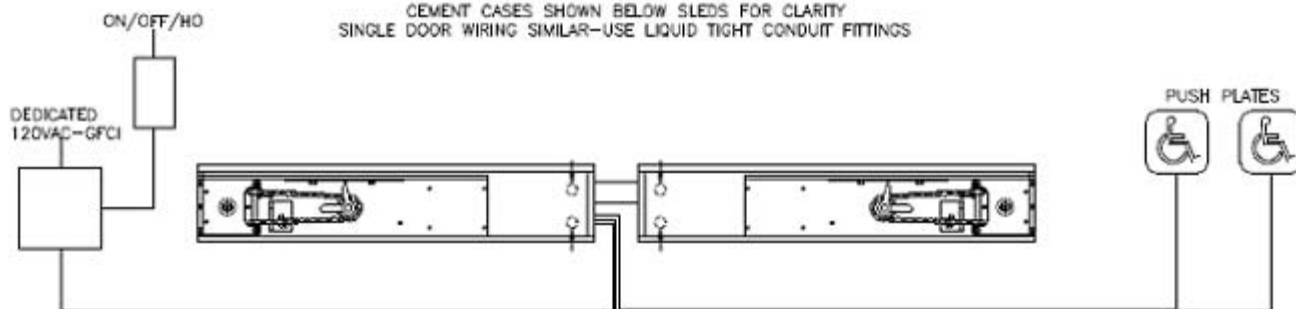

PLAN VIEW SCALE = 1:16

WIRING REQUIREMENTS ELECTRIC PANIC DEVICE INSTALLATION

ALL WIRING TO NON-PIVOT SIDE OF DOOR LEAF. WIRES TO CENTER ON PAIRS; WIRES TO STRIKE SIDE ON SINGLES. SEE ELECTRICAL PENETRATION DRAWING IN MANUAL FOR CONDUIT FITTING LOCATION ON CEMENT CASE. SEE OPERATOR/DEVICE MANUFACTURER'S MANUAL FOR SPECIFIC WIRING

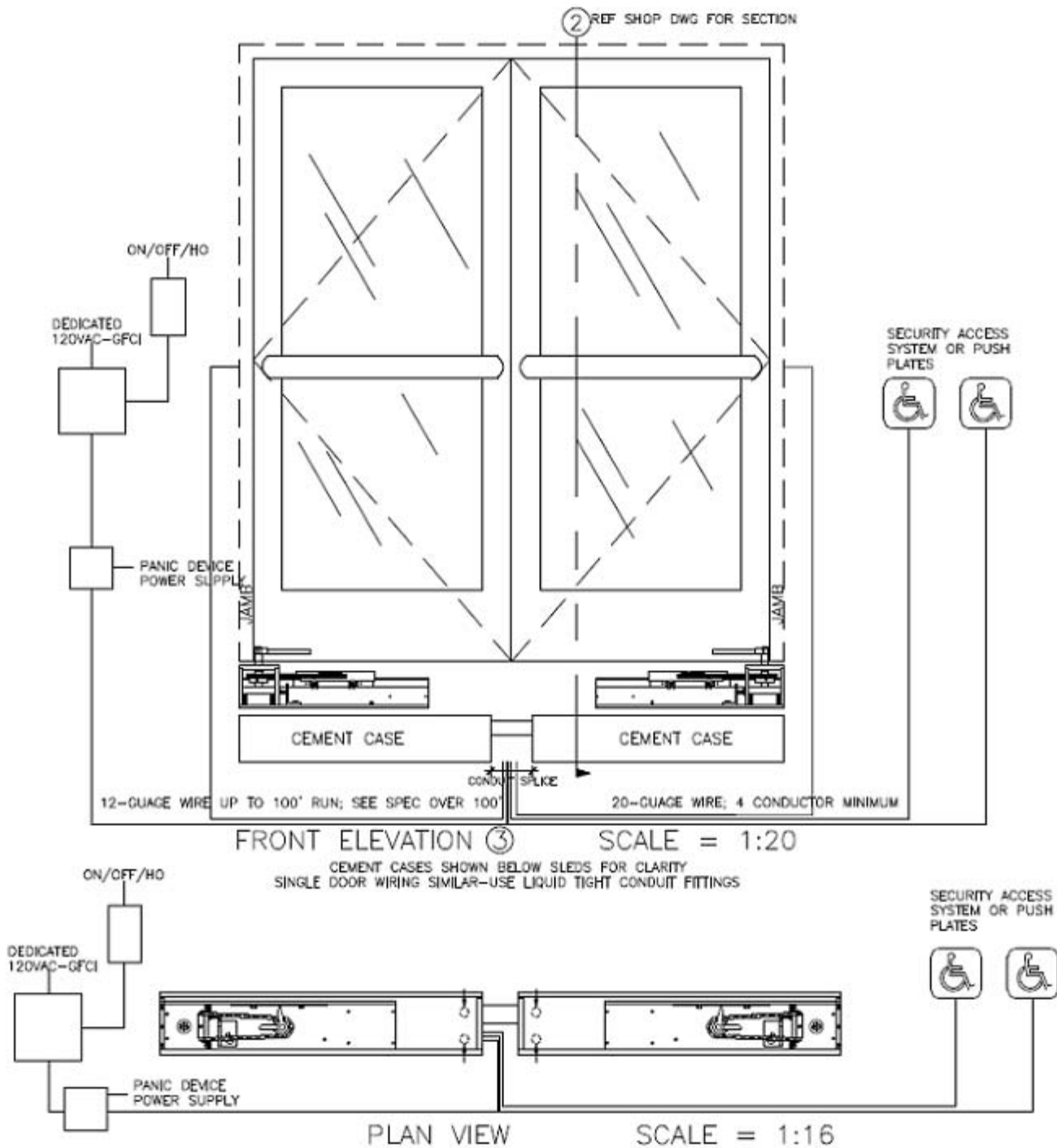

WIRING REQUIREMENTS OVERHEAD LOCK INSTALL

ALL WIRING TO NON-PIVOT SIDE OF DOOR LEAF. WIRES TO CENTER ON PAIRS;
WIRES TO STRIKE SIDE ON SINGLES. SEE ELECTRICAL PENETRATION DRAWING IN
MANUAL FOR CONDUIT FITTING LOCATION ON CEMENT CASE. SEE LOCK &
OPERATOR MANUFACTURER'S MANUALS FOR SPECIFIC WIRING REQUIREMENTS

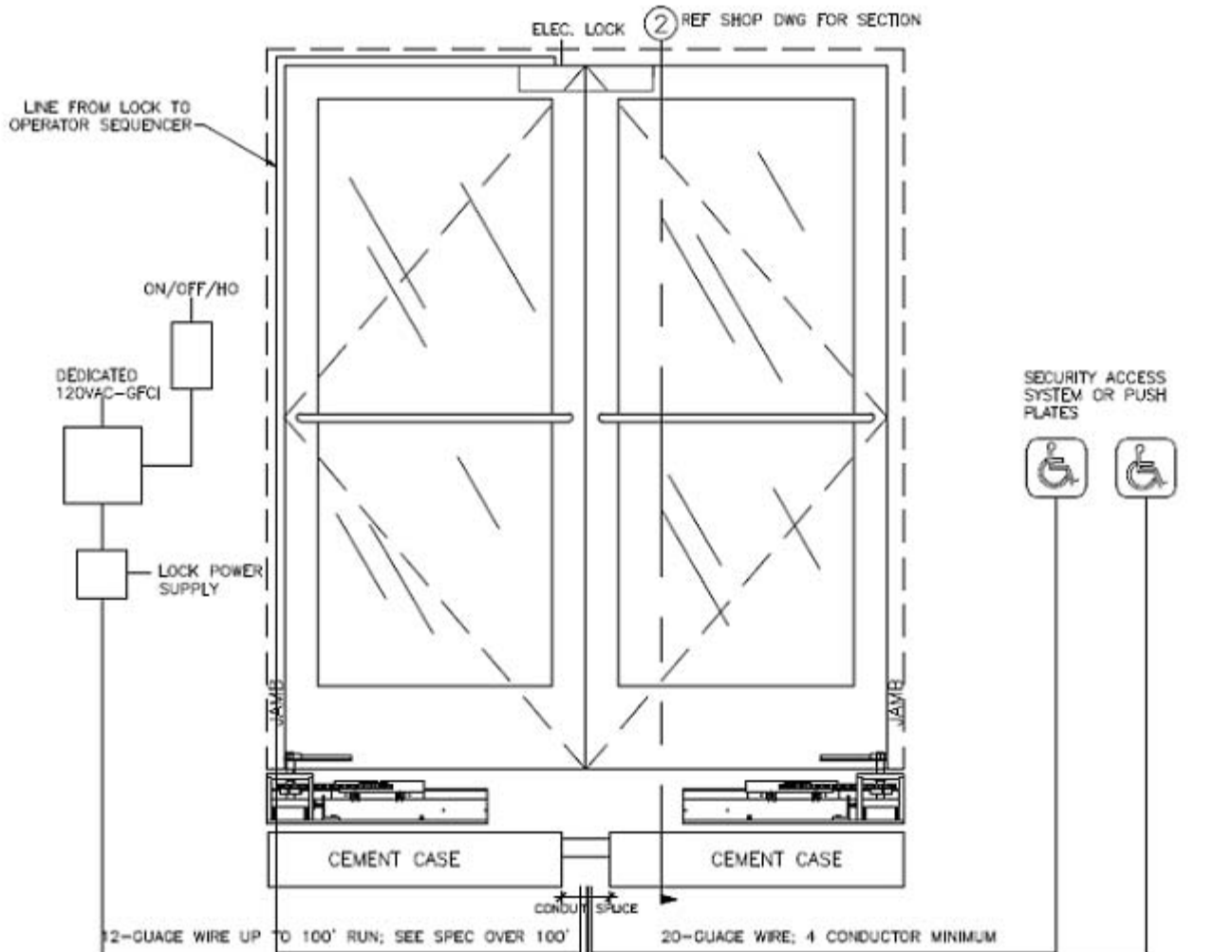

FRONT ELEVATION ③ SCALE = 1:20

CEMENT CASES SHOWN BELOW SLEDS FOR CLARITY
SINGLE DOOR WIRING SIMILAR—USE LIQUID TIGHT CONDUIT FITTINGS

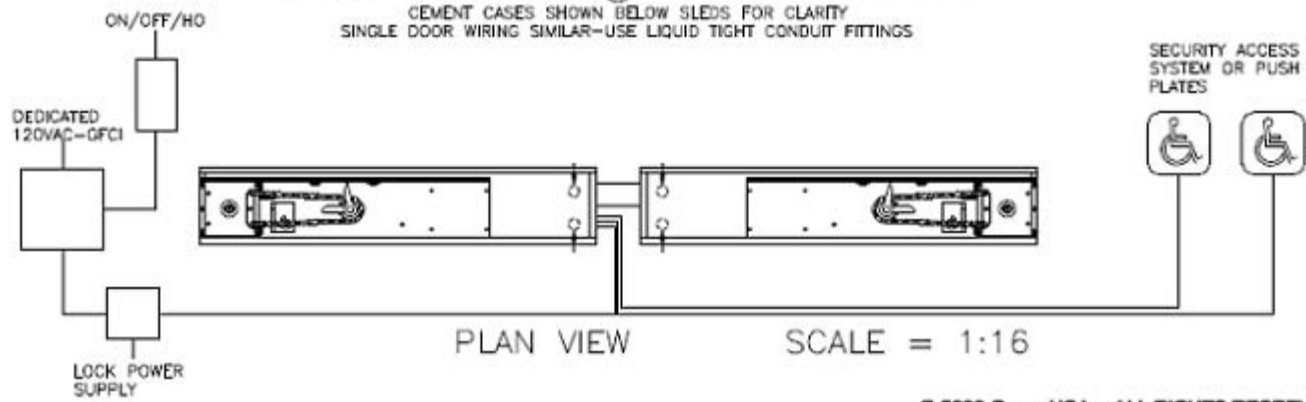

PLAN VIEW SCALE = 1:16

WIRING REQUIREMENTS BOTTOM LOCK INSTALL

ALL WIRING TO NON-PIVOT SIDE OF DOOR LEAF. WIRES TO CENTER ON PAIRS;
WIRES TO STRIKE SIDE ON SINGLES. SEE ELECTRICAL PENETRATION DRAWING IN
MANUAL FOR CONDUIT FITTING LOCATION ON CEMENT CASE. SEE LOCK &
OPERATOR MANUFACTURER'S MANUALS FOR SPECIFIC WIRING REQUIREMENTS



NOTE: REQUIRES IN-FIELD FABRICATION/MODIFICATION TO THRESHOLD & CEMENT
CASE. ADEQUATE AND APPROPRIATE SEALANT IS REQUIRED AT LOCK PENETRATIONS.
WATERPROOF SEAL IS THE RESPONSIBILITY OF THE INSTALLER

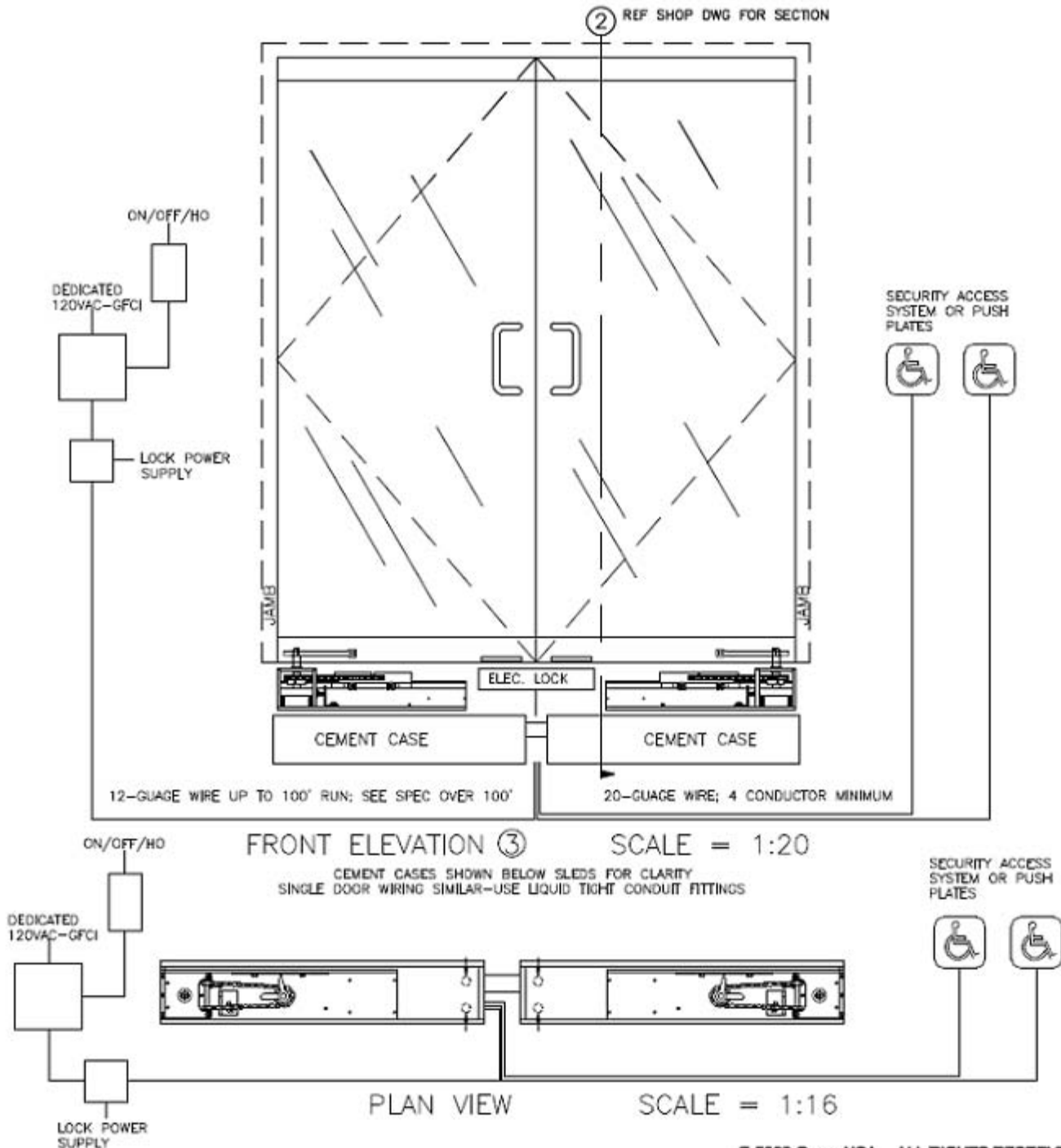

OPCON MANUFACTURING SYSTEMS, INC.

WARRANTY POLICY ON OPCON PRODUCTS

Opcon Manufacturing Systems, Inc. (Opcon) manufactures its products from high-grade materials with first class workmanship. Subject to the other conditions of the **Warranty**, if any parts of our own manufacture prove defective in material or workmanship within one (1) year after original installation, we shall repair or replace such parts free of cost. If any equipment or parts not of our own manufacture are utilized in connection with this automatic door operator conversion system, we shall assume responsibility and liability for defects only to the extent of such adjustment as the manufacturer thereof makes to us. The warranty shall not extend beyond one (1) year from the original date of installation regardless of any replacements that may be made. This is a parts replacement warranty. Field labor shall be the responsibility of the installing or servicing entity.

Our obligations under this **Warranty** are conditional upon (1) the owner's having filed the **Warranty** Registration Card with us at the time of the original installation, (2) giving us prompt written notice of alleged defects, and (3) upon our request, returning the allegedly defective items to us in Carlsbad, California, freight prepaid, for our inspection.

We shall have no obligation or liability, under this **Warranty** or otherwise, in the event of improper installation of this automatic door operator conversion system unless and until the installation is corrected. However, in no case shall we have any obligation or liability beyond one (1) year after the original installation for any replacement or repairs that may be made. We reserve the right, without obligation, to inspect all installations of Opcon door operator conversion systems and equipment for the protection of both the owner and ourselves. Only authorized automatic door installers may install or service the Opcon conversion system and/or the interfaced automatic door operator equipment.

In no event shall we have any obligation or liability, under this **Warranty** or otherwise, resulting in whole or in part from damage to defects in the door operator or equipment caused by abuse, misuse, malicious mischief, acts of God, casualty, improper handling or the negligence of the owner or others. Nor shall we have any obligation or liability for any loss, cost or expense incurred in the repair or replacement of the door operator or equipment except on express written authority from our office in Carlsbad, California.

The owner's sole remedy against us for any alleged defects in the Opcon Conversion System shall be as provided in this **Warranty**. We hereby disclaim all other obligations and liability for damages, including any incidental consequential damages. **THIS WARRANTY IS IN LIEU OF ALL OTHER WARRANTIES, EXPRESSED OR IMPLIED, INCLUDING ANY IMPLIED WARRANTY OF MERCHANTABILITY OR FITNESS FOR A PARTICULAR PURPOSE.**

This **Warranty** may not be changed, expanded or modified in any way. Any warranty requiring field labor is the responsibility of the Opcon factory-authorized installer.

COPYRIGHT WARNING

ALL DRAWINGS AND WRITTEN MATERIAL APPEARING HEREIN CONSTITUTE THE ORIGINAL PUBLISHED AND UNPUBLISHED WORK OF OPCON MANUFACTURING SYSTEMS, INC AND MAY NOT BE DUPLICATED, USED OR DISCLOSED WITHOUT THE WRITTEN CONSENT OF OPCON MANUFACTURING SYSTEMS, INC.

PATENT WARNING

THE EQUIPMENT APPEARING HEREIN, BOTH WRITTEN AND DRAWN, REFERENCES PATENTED PRODUCTS OWNED ENTIRELY BY OPCON MANUFACTURING SYSTEMS, INC. ANY REPRODUCTION OF THE EQUIPMENT BY METHODOLOGY, MANUFACTURING, OR USE IS FORBIDDEN BY LAW. OPCON MANUFACTURING SYSTEMS, INC SHALL TAKE ALL NECESSARY LEGAL ACTION TO PROTECT THE PROPRIETARY INFORMATION CONTAINED HEREIN.



US006176044B1

(12) **United States Patent**
Nixon et al.

(10) Patent No.: **US 6,176,044 B1**
(45) Date of Patent: ***Jan. 23, 2001**

(54) UNDERGROUND DOOR OPERATING APPARATUS AND METHOD	1,537,575 * 6/1927 Koblus et al. 49/334
	3,210,067 * 10/1965 Ferguson et al. 49/334
	3,864,873 * 2/1975 Heerdt 49/334
(73) Inventor: Angelo Nixon, Carlsbad; Edward Preston Murphy, Menzies, both of CA (US)	4,599,024 * 7/1985 Mizukoshi et al. 49/334
	5,036,620 * 8/1991 Beni et al. 49/334
	5,123,204 * 6/1992 He 49/334
	5,417,011 * 5/1995 Keszeily 49/334

(73) Assignor: Opcon Manufacturing Systems, Inc. Carlsbad, CA (US)

* cited by examiner

(*) Notice: This patent issued on a continued prosecution application filed under 37 CFR 1.53(d), and is subject to the twenty year patent term provisions of 35 U.S.C. 154(a)(2).

Under 35 U.S.C. 154(b), the term of this patent shall be extended for 0 days.

(21) Appl. No.: 08/932,528

(22) Filed: Sep. 18, 1997

(51) Int. Cl.⁷ B06B 3/00; B05F 15/02

(52) U.S. Cl. 49/305; 49/334

(58) Field of Search 49/333, 334, 335, 49/336, 339, 343, 341, 506

(56) **References Cited**

U.S. PATENT DOCUMENTS

1,120,391 * 2/1915 Fisher et al. 49/334
1,367,931 * 2/1921 Armon 49/334

Primary Examiner—Daniel P. Stodola
Assistant Examiner—Curtis A. Cohen
(74) *Attorney, Agent, or Firm*—Myers, Dawes & Anderson, LLP

(57) **ABSTRACT**

A door assembly includes a door automatically operable relative to a floor and further comprises an electromechanical power device disposed beneath the floor and providing a rotary output on a shaft. The support apparatus includes a spindle adapted to receive power from the rotary shaft beneath the floor and to extend above the floor into a coupled relationship with the door. A bearing included in the support apparatus supports the spindle and at least a portion of the weight of the door beneath the floor. The electromechanical device can be of the type commonly used in overhead systems, in which case the power device can be associated with the support apparatus for disposition beneath the floor. A coupling mechanism in the support apparatus can include pulleys, sprockets and gears, and power transfer devices such as belts and chains.

14 Claims, 2 Drawing Sheets

PATENT NUMBER:

US 6,176,044 B1 OF 2001

PATENTS PENDING:

PUB. NO. 2008/0256869 A1
SEALING ARRANGEMENT
FOR DOOR OPERATING
APPARATUS

PUB. NO. 2008/0256870 A1
ADJUSTABLE SPINDLE
ARRANGEMENT FOR DOOR
OPERATING APPARATUS

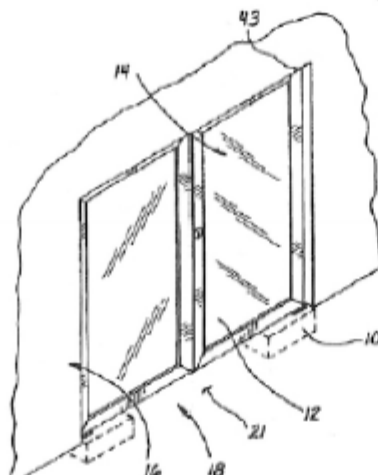

**Opcon Manufacturing
Systems, Inc.**
P.O. Box 308
Carlsbad, CA 92018



Phone: (760) 720-3902
Fax: (760) 720-9653
Sales@OpconUSA.com
<http://www.opconusa.com>

© OpconUSA All rights reserved. Printed in the U.S.A.
Opcon Manufacturing Systems, Inc. reserves the right to make all necessary product changes without notice.